



Installation and Maintenance Manual for model

R2K 34 RAIN

Condensing boiler with integrated heat exchanger for domestic hot water side, suitable for outdoor installation



Contact Details

Office Address: 10 Frankston Gardens Drive,
Carrum Downs, Victoria, Australia, 3201

Email Address: sales@hydronicsupplies.com.au

Website: www.hydronicsupplies.com.au

Phone: (+61 3) 9708 2600

Fax: (+61 3) 9708 2700



TABLE OF CONTENTS

INTRODUCTION	5
--------------------	---

1. INSTALLER SECTION 7

1.1. INSTALLATION	8
1.1.1. GENERAL INSTALLATION WARNINGS	8
1.1.2. BOILER LOCATION ENVIRONMENTAL REQUIREMENTS	8
1.1.3. REFERENCE LEGISLATION	9
1.1.4. UNPACKING	10
1.1.5. POSITIONING AND MINIMAL TECHNICAL SPACES	11
1.1.6. OVERALL DIMENSIONS	13
1.1.7. JIG	13
1.1.8. CIRCULATOR PREVALENCE/FLOW DIAGRAM	14
1.1.9. CHECK LIST	15
1.1.10. HYDRAULIC CONNECTION	16
1.1.11. SYSTEM FILLING	17
1.1.12. FILLING THE CONDENSATE COLLECTION SIPHON	18
1.1.13. ANTI-FREEZE PROTECTION	19
1.1.14. GAS CONNECTION	20
1.1.15. ELECTRICAL CONNECTION	20
1.1.16. POWER SUPPLY	21
1.1.17. OPTIONAL ELECTRICAL CONNECTIONS	22
1.1.18. FUME EXHAUST FITTINGS	24
1.1.19. TYPES OF FUME EXHAUST SYSTEMS	26

2. SUPPORT CENTRE SECTION 29

2.1. FIRST START-UP	30
2.1.1. PRELIMINARY OPERATIONS FOR FIRST START-UP	30
2.1.2. BOILER COMMISSIONING	31
2.1.3. CO2 VALUE CHECK AND CALIBRATION	32
2.1.4. ACCESSING AND PROGRAMMING THE PARAMETERS	33
2.1.5. DIGITECH CS PARAMETERS TABLE	35
2.1.6. ELECTRIC FAN FREQUENCY/HEAT CAPACITY DIAGRAM	43
2.2. MAINTENANCE	44
2.2.7. GENERAL MAINTENANCE WARNINGS	44
2.2.8. TECHNICAL DATA	46
2.2.9. TECHNICAL ASSEMBLY	48
2.2.10. HYDRAULIC BOARD	49
2.2.11. 3-WAY VALVE OPERATION	50
2.2.12. WIRING DIAGRAM	51



TABLE OF CONTENTS

2.2.13. ACCESSING THE BOILER.....	52
2.2.14. ACCESSING THE ELECTRONIC BOARD.....	53
2.2.15. SYSTEM EMPTYING.....	54
2.2.16. FAULT SIGNALLING CODES.....	55
2.2.17. ACTIVE FUNCTIONS SIGNALLING CODES.....	59
2.2.18. GAS CONVERSION.....	60



INTRODUCTION

WARNING

Before starting any operation it is mandatory to read this instruction manual, in relation to the activities to be carried out as described in each relevant section. Proper operation and optimal performance of the boiler are ensured by strict compliance with all the instructions given in this manual.

The installation, use and maintenance manual is an integral and essential part of the product and must be delivered to the user.

MANUAL USERS

The manual users are all those who install, use and maintain the boiler.

The boiler must be used and accessed only by qualified operators that fully read and understood the use and maintenance manual, paying particular attention to the warnings.

READING AND SYMBOLS OF THE MANUAL

To ease the understanding of this manual, recurrent symbols where used, in particular:

- › On the outer margin of the page is placed a thumb index indicating the type of user to which the instructions in that section address.
- › The titles are differentiated by thickness and size in accordance with their hierarchy.
- › The images contain important parts described in the text, marked with numbers or letters.
- › [See chap "chapter name"]: this entry indicates another section in the Manual that you should refer to.
- › Device: this term is used referring to the boiler.



DANGER

It identifies an information related to a general danger that if not complied with, may cause serious personal damage or even death.



ATTENTION

It identifies an information that if not complied with may cause small or medium level lesions to the person or serious deterioration to the boiler.



WARNING

It identifies a precaution information that must be observed in order to avoid damaging the machine or parts of it.

MANUAL STORAGE

The manual must be carefully stored and replaced in case of deterioration and/or low legibility.

If you misplace the use and maintenance manual, you can request it from the Technical Support Centre giving the serial number and model of the boiler indicated on the plate placed on the right side of its casing.

As an alternative, the use and maintenance manual can be downloaded free from the on-line site www.radiant.it, accessing the "download" section and entering the boiler model.



WARNING

DO NOT SPRAY AEROSOLS IN THE VICINITY OF THIS APPLIANCE WHILE IT IS IN OPERATION.

DO NOT USE OR STORE FLAMMABLE MATERIALS IN OR NEAR THIS APPLIANCE.

DO NOT PLACE ARTICLES ON OR AGAINST THIS APPLIANCE.

DO NOT MODIFY THIS APPLIANCE.



MANUFACTURER WARRANTY AND RESPONSIBILITY

The warranty of the Manufacturer is provided only through its own authorized Technical Support Centres, listed for each Region and Province on the site www.radiant.it, and covers all conformity defects at the moment of sale.

The technical and functional features of the device are ensured by its use in compliance:

1. with the use and maintenance instructions contained in the manuals accompanying the product, the content of which the customer certifies that he is aware;
2. with the conditions and purposes to which assets of the same type are intended.

For more information on the warranty validity, its duration, the obligations and the exemptions, please consult the First start-up certificate attached to this manual.

The manufacturer reserves:

- › the right to modify the tools and relative technical documentation without any obligation to third parties; neither will the company be held responsible for any inaccuracies in this handbook deriving from printing or translation errors;
- › the material and intellectual ownership of this manual and forbids its distribution and duplication, even partial, without prior written authorization.



1. INSTALLER SECTION

The installation operations described in this section should be performed only by qualified personnel, having the appropriate technical training in the field for the installation and maintenance of components of civil and industrial domestic hot water production and heating plants.



1.1. INSTALLATION

1.1.1. GENERAL INSTALLATION WARNINGS



ATTENTION

This machine may be used only for the purpose for which it has been designed: heat water to a temperature below boiling point at atmospheric pressure. Any other use is considered wrong and dangerous. The manufacturer is excluded from any contractual or out of contract responsibility for damage caused to people, animals or property due to errors during installation.



ATTENTION

This boiler should be installed only by qualified personnel, having the appropriate technical training in the field for the installation and maintenance of components of civil and industrial domestic hot water production and heating plants.



ATTENTION

After having removed the packing, make sure the equipment is intact. In case of doubt, do not use the equipment and contact the supplier.



ATTENTION

This Appliance must be used exclusively in a pressurized central heating system and is not suitable for pool heating.

BEFORE INSTALLING THE BOILER, THE INSTALLER MUST MAKE SURE THAT THE FOLLOWING CONDITIONS ARE MET:

- › The device is connected to a heating plant and a water supply network appropriate for its power and performance.
- › The location must be properly vented through an air vent.

- › The air vent must be placed at floor level to prevent it from being obstructed, protected by a grid that does not hamper the useful section of passage.
- › The device is suitable for use with the type of gas available by checking the boiler data plate (placed on the inner side of the front casing).
- › Make sure that the tubes and couplings are perfectly sealed, without any gas leaks.
- › Make sure that the grounding system works properly.
- › Make sure that the electrical systems is suitable for the maximum power absorbed by the equipment, value indicated on the data plate.



WARNING

Use only original RADIANT optional or kit accessories (including electrical).

1.1.2. BOILER LOCATION ENVIRONMENTAL REQUIREMENTS

The device's installation location should be vented due to the presence of threaded joints on the gas adduction line. The location should be therefore provided with vents as to ensure air exchange, with output grid in the natural accumulation area of eventual gas losses.



WARNING

DO NOT install the boiler in a technical compartment near a swimming pool or a laundry, to avoid that the combustion air is exposed to chlorine, ammonia or alkaline agents that may worsen the corrosion phenomenon of the heat exchanger. Failure



to observe this caution will void the warranty of the heat exchanger.

THIS BOILER HAS BEEN DESIGNED FOR OUTDOOR INSTALLATION IN A PARTIALLY PROTECTED LOCATION (SEE FIG.2 AT CHAPTER 'POSITIONING AND MINIMAL TECHNICAL SPACES').

The ABS material boiler casing is approved for the exposition to atmospheric agents and, in particular, to UV rays.

THIS BOILER IS ABLE TO OPERATE IN A PARTIALLY PROTECTED PLACE, WITHIN THE AMBIENT TEMPERATURES MINIMUM -10 °C AND MAXIMUM 60 °C.

**WARNING**

If the temperature in the boiler installation location goes below -10° centigrades, please fill the plant with anti-freeze liquid and insert and electrical resistances kit (see chapter 'ANTI-FREEZE PROTECTION').

**WARNING**

The manufacturer will not be held responsible for damages caused by incorrect installation not in conformity with the over mentioned instructions and not protected adequately from the freeze.

1.1.3. REFERENCE LEGISLATION

The installation must be realized according to the requirements of current legislation and in compliance with local technical regulations, according to the indications of the good technique.

This appliance must be installed by an authorised person in accordance with this instruction manual, AS/NZS 5601 – Gas installations (installation and pipe sizing), local gas fitting regulations, local electrical regulations, local water regulations, local health regulations, Building Code of Australia and any other government authority.



1. INSTALLATION

1.1.4. UNPACKING



WARNING

Please unpack the boiler just before installing it. The Company is not responsible for the damages caused to the device due to incorrect storage.



WARNING

The packing elements (cardboard box, wooden crate, nails, fasteners, plastic bags, expanded polystyrene, etc.) must be kept out of the reach of children as they may be dangerous. Therefore they should be dismantled suitably differentiating them in accordance with the standards in force.

To unpack the boiler, proceed as follows:

- > Place the packed boiler on the floor (fig. 1-A) and remove the fasteners opening the four flaps of the box outwards.
- > Turn the boiler at 90° holding it with your hand (fig. 1-B).
- > Lift the box (fig. 1-C) and remove the guards (fig. 1-D).

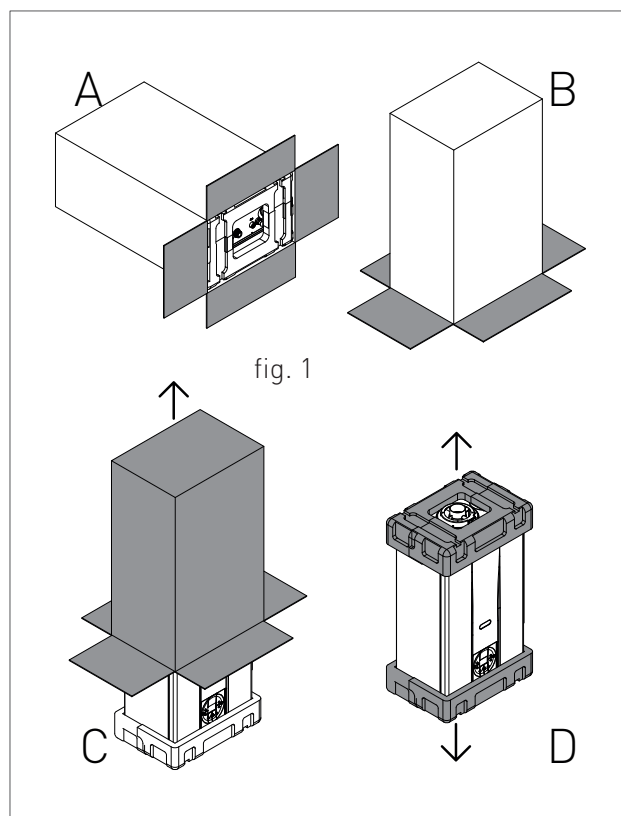

1.1.5. POSITIONING AND MINIMAL TECHNICAL SPACES

The boiler must be installed only on a vertical solid wall, able to sustain its weight.

In order to allow the access inside the boiler for maintenance operations, you have to respect the minimum technical spaces indicated in figure 1.

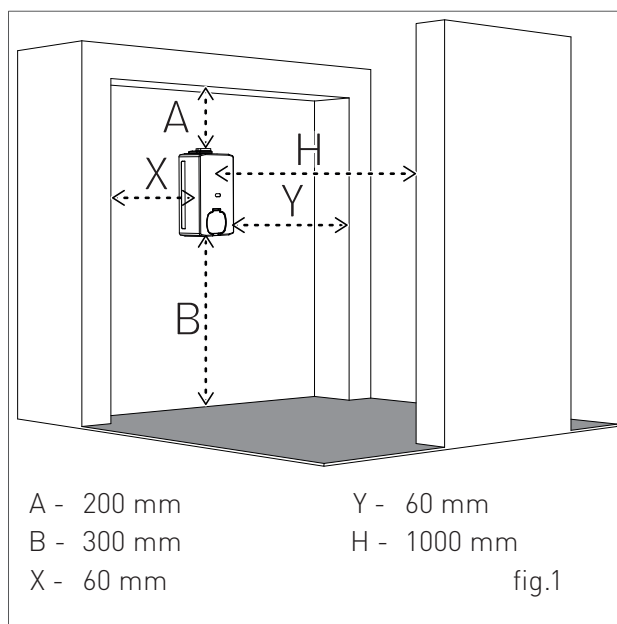

It is allowed an outdoor installation in a partially protected location (i.e. shelter, balcony) that respect the minimum measure indicated in figure 2.

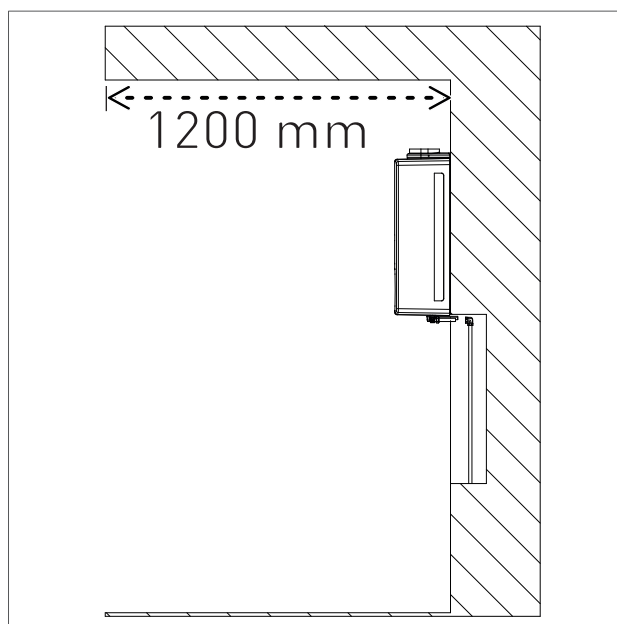



1. INSTALLATION

To facilitate the installation, the boiler is provided with a jig that allows setting in advance the connections to the tubes offering you the possibility of connecting the boiler to completed masonry works.

For machine positioning, proceed as follows (see fig. 3):

1. Trace a line using a spirit level (min. length 25 cm) on the installation wall.
2. place the top of the jig along the traced line respecting the distances of the water connections; then mark the two points to insert the two knobs or the fasteners, then trace the points for the fume exhaust fittings;
3. remove the jig and drill the wall;
4. hang the device using the knobs or the bracket and perform the connections.

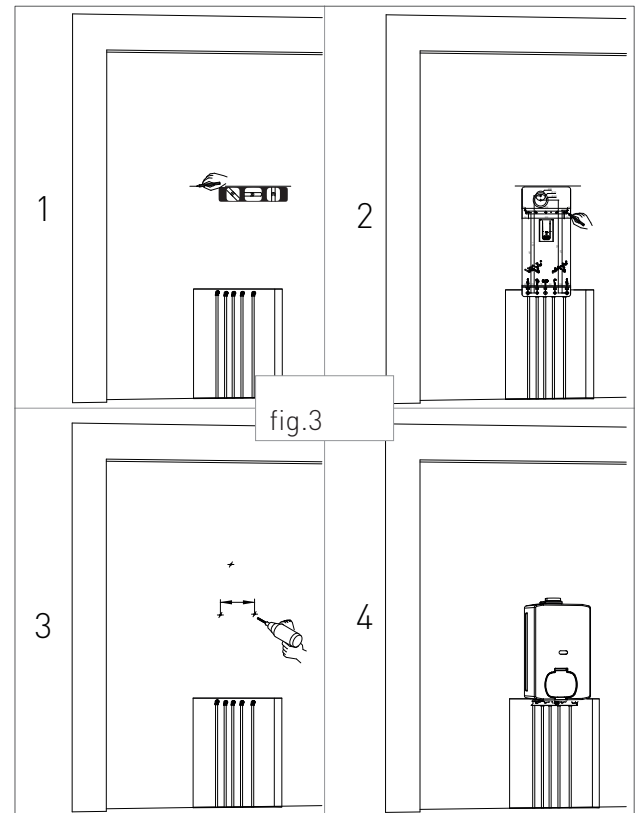



1.1.6. OVERALL DIMENSIONS

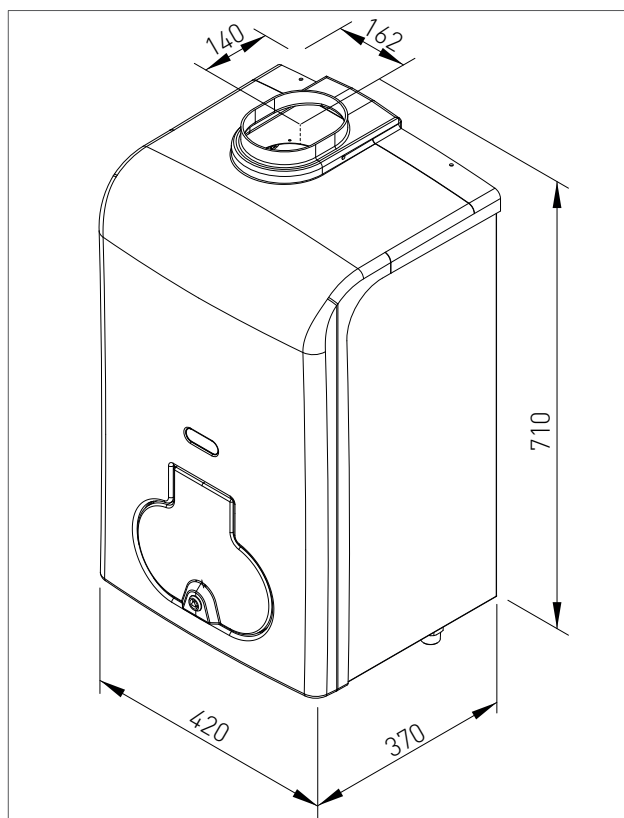

1.1.7. JIG

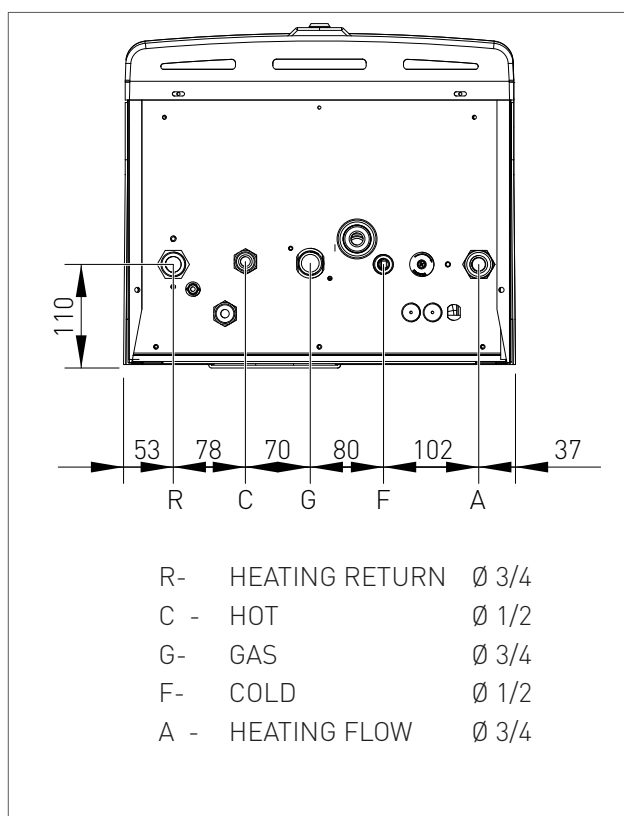

1 Dimensioni_R2K RAIN_EN



1. INSTALLATION

INSTALLER



WARNING

Make sure, using a level, that the boiler is properly inclined being levelled (see fig.1) so as to allow the condense to drain.

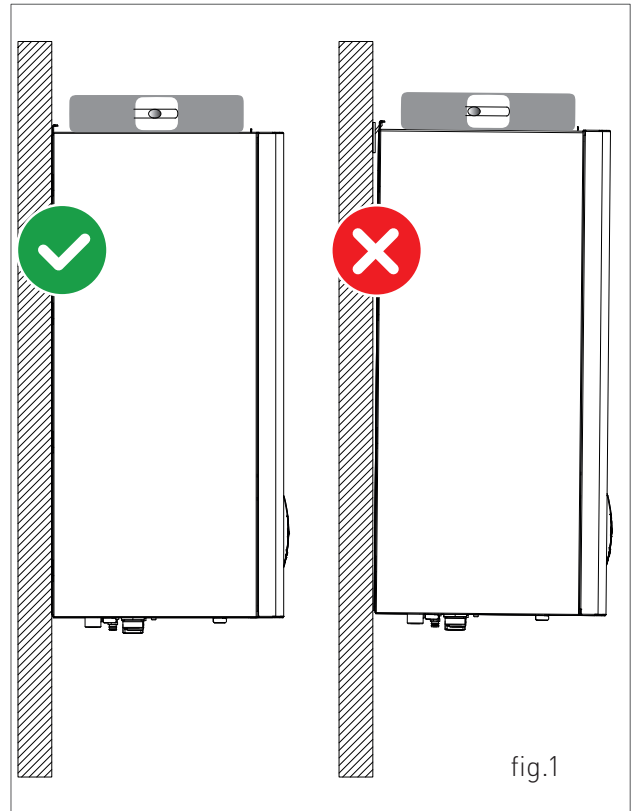
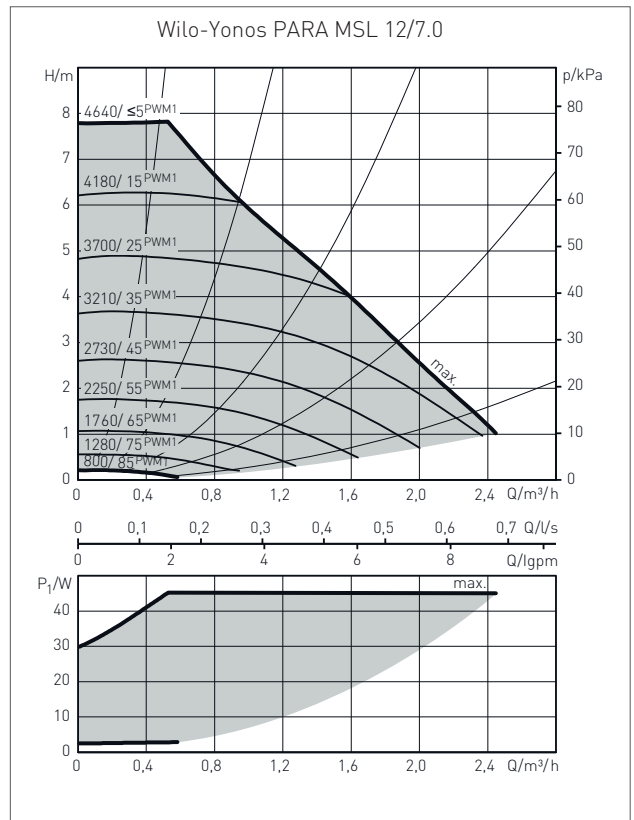
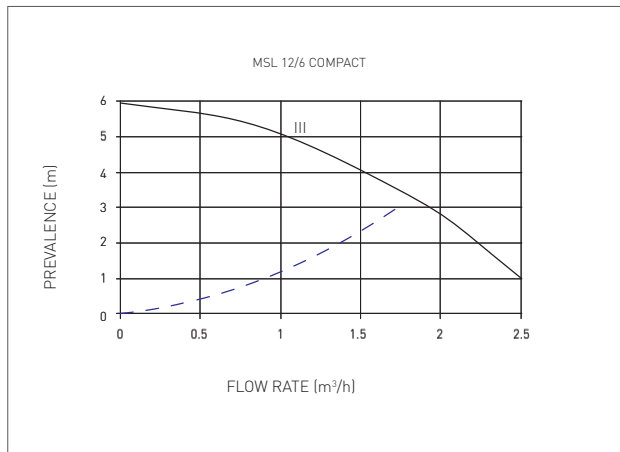

fig.1

1.1.8. CIRCULATOR PREVALENCE/FLOW DIAGRAM



- III — Circulator priority maximum speed
- Appliance Loss

Diagrammportata-prevalenzacirculatore_R2K24_V3_EN



1.1.9. CHECK LIST

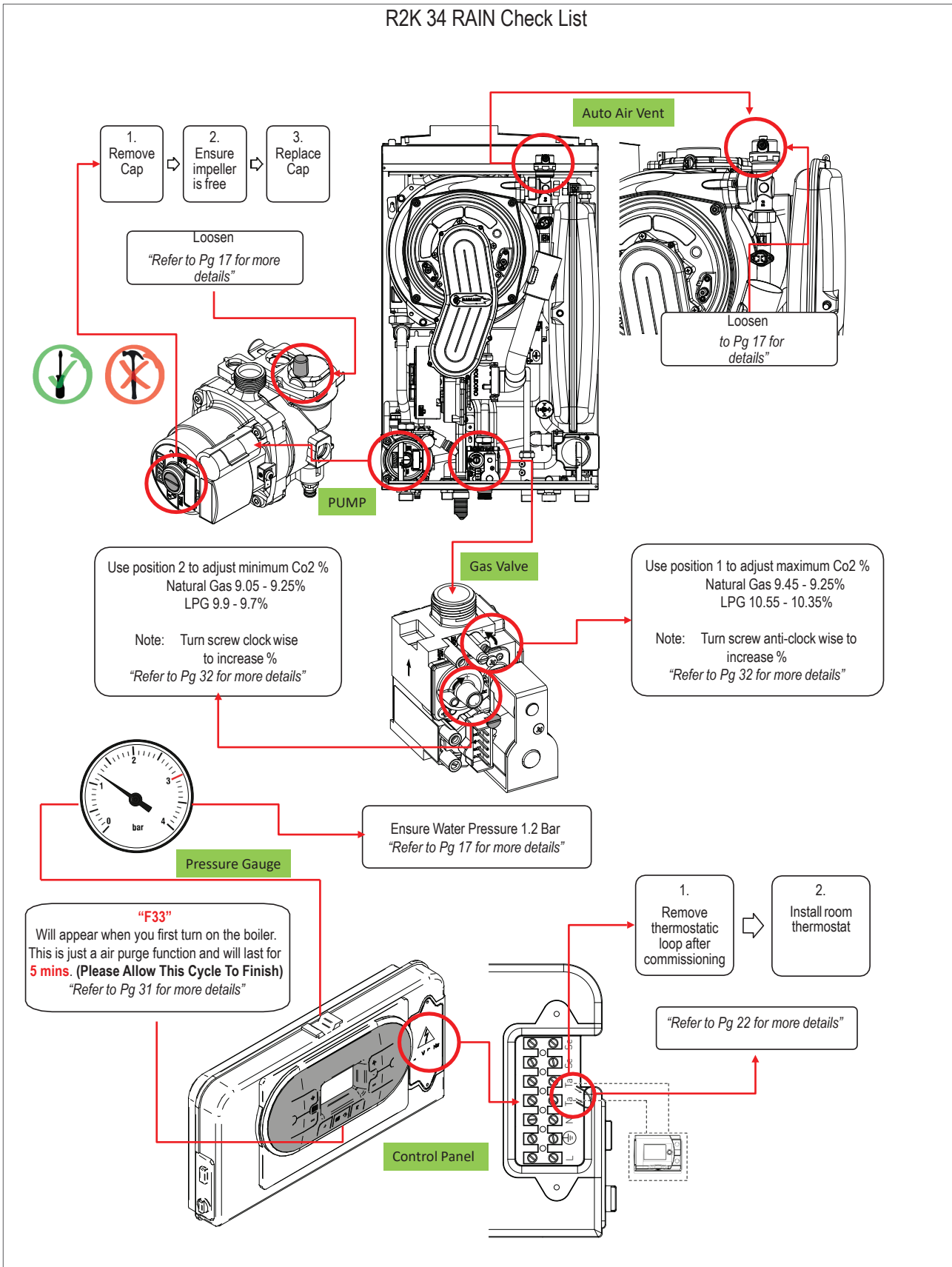

1.1.10. HYDRAULIC CONNECTION

**DANGER**

Make sure that the tubes of the water and heating plant are not used as grounding system for the electrical plant. There are not suitable for such use.

**WARNING**

To prevent voiding the warranty and to ensure the proper operation of the boiler, please wash the plant (if possible when hot) with suitable pickling or descaling solutions in order to remove the impurities coming from tubes and radiators.

**WARNING**

If the boiler is installed in a hydrostatic position lower than those of the user devices (radiators, fan coils, etc.), mount the shut-off valves on the domestic water heating circuit to ease the performance of the maintenance operations if it is necessary only to empty the boiler.

**WARNING**

When connecting the equipment to water supply, avoid excessive bending and recovery operations from any off axis positioning that may damage the tubes causing leaks, malfunction or early wear.

**WARNING**

In order to avoid any vibrations and noises, do not use tubes with small diameters or elbows with small radius and significant cut-off of the passage sections.

**WARNING**

Connect the boiler safety drains to a discharge funnel. The manufacturer is not responsible for any floods due to safety valve opening in case of plant overpressure.

DOMESTIC CIRCUIT

In order to prevent limestone build-up and damages to the domestic water heat exchanger, the hardness of the domestic supply water should not exceed 15 °f. However, please check the characteristics of the water used and install suitable treating devices.

The heat exchanger coil cleaning frequency depends on the hardness of the supply water and on the presence of solid residues or impurities inside the water that are often present in case of recently installed plants. Based on the characteristics of the infeed water, you should install suitable water treating devices, for residues presence please install a line filter.

The pressure of the cold infeed water should be between 0.5 and 6 bar. In case of greater pressure values, please install a pressure reducer upstream from the boiler.

HEATING CIRCUIT

In order to avoid any scale or deposits on the primary exchanger, the hardness of the heating circuit infeed water should not exceed 25 °f. However, please check the characteristics of the water used and install suitable treating devices.

This treatment is mandatory if frequent episodes of return water or partial or total emptying of the plant occur.

**WARNING**

In case the boiler is installed as part of a low temperature circuit, please install a safety thermostat on the heating flow, which can stop the boiler activity in case of high heating flow temperature. The company assumes no liability for damage caused to persons or for failure to comply with these instructions.

1.1.11. SYSTEM FILLING

**WARNING**

For system filling use only clean tap water.

**WARNING**

If the system is filled by adding ethylene glycol-type chemical agents you have to install on the loading system a hydraulic trip unit in order to separate the heating circuit from the domestic circuit.

Before powering up the boiler, fill the system as follows:

1. Make sure the circulator is not blocked;
2. slightly loosen the cap of the circulator auto air vent (1-fig. 1) to release the air from the system;
3. slightly loosen the cap of the auto air vent placed on the top of the condensing block (fig. 3) to release the air form the top of the system;
4. open the feeding tap "R" (fig. 2);
5. release all the air;
6. use pressure gauge "M" (fig. 2) to make sure that the system pressure reaches 1.2 bar (fig. 4);
7. after performing this operation, make sure that the loading tap "R" (fig. 2) is properly closed.
8. Unscrew the circulator cap (2-fig.1) to release any air bubbles and close it to prevent water leakage;

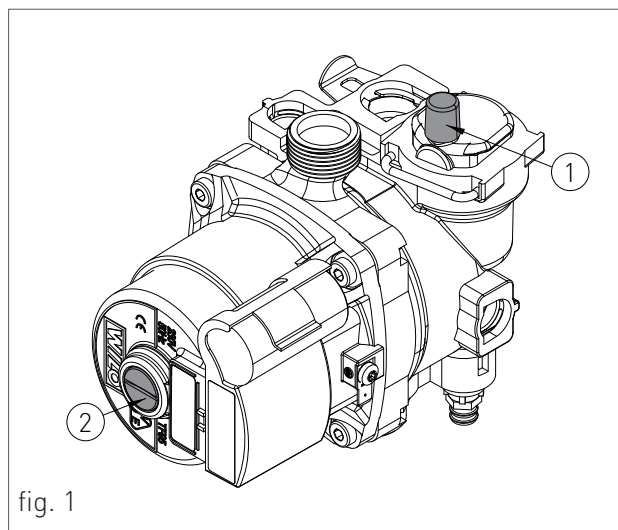

fig. 1

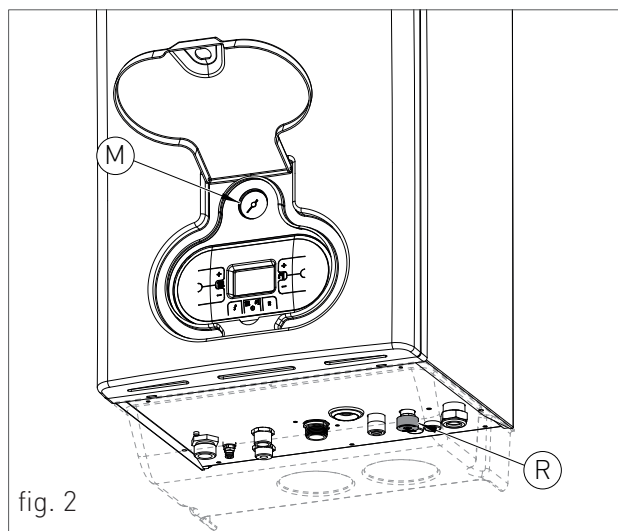

fig. 2

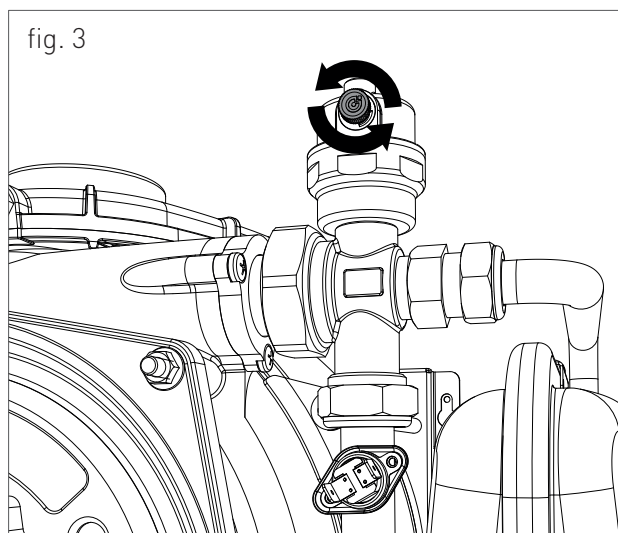

fig. 3



1. INSTALLATION

9. open the air relief valves of the radiators and check the air removal process. When the water starts to leak close the radiators air relief valves.
10. If after performing these operations you observe a decrease of the water pressure inside the system, open once again the loading tap "R" until the pressure gauge indicates the value of 1.2 bar (fig. 4).

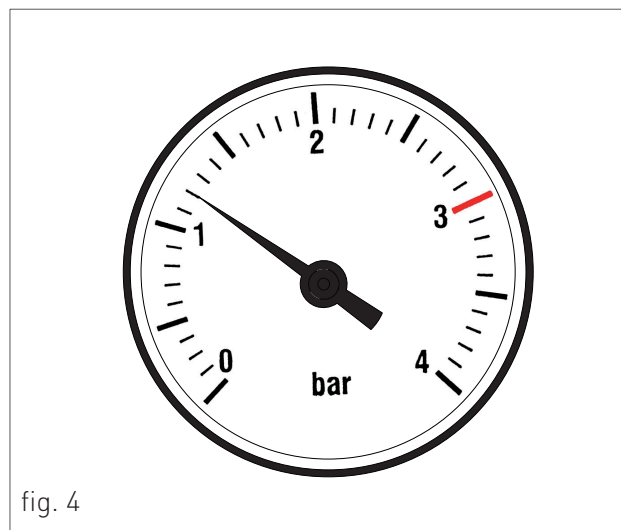

fig. 4

1.1.12. FILLING THE CONDENSATE COLLECTION SIPHON

Before starting the boiler you have to fill the condensate collection siphon in order to avoid fuel reflux through the siphon.

Fill the condensate collection siphon as follows (see fig. 5):

- › With a glass pour the water in the heat exchanger's flue exhaust duct outlet (see fig. 5), up to fill the condensate trap to the highest point "T" (fig. 5);
- › Connect the dedicated flexible condensate draining tube to a waste disposal system. The condensate can be drained directly in the sewerage system by inserting an easily serviceable siphon.

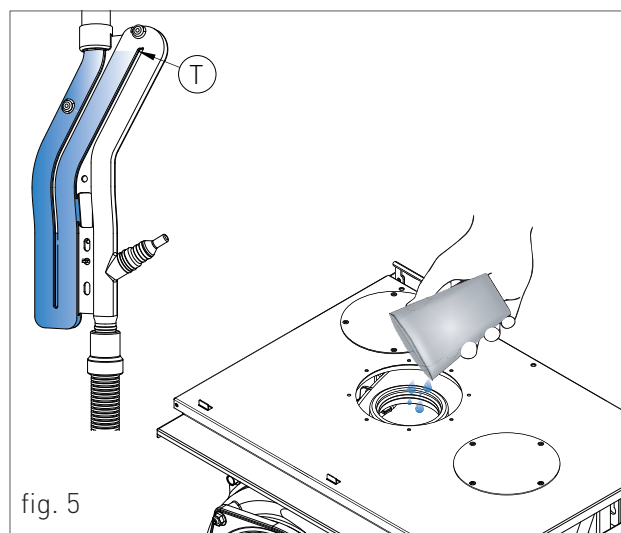

fig. 5



1.1.13. ANTI-FREEZE PROTECTION

The boiler is protected against freezing thanks to the electronic board preparation with functions that start the burner and heat the concerned parts when their temperature goes below the minimum pre-set values, protecting the boiler up to an external temperature of -10 °C.

The device starts when the hot water temperature goes below 8 °C, automatically starting the burner until the heating flow water temperature reaches the 30°C and, in presence of a return sensor, until the heating return water temperature reaches the 20°C.

The system starts even if on the display appears "OFF", as long as the boiler is connected to the power (230 V) and gas supply.

For long periods of standby, please empty the boiler and the plant.

If the temperature goes below -10° centigrades, please fill the plant with anti-freeze liquid (CLEANPASS FLUIDO AG cod. 98716LA) and insert and electrical resistances kit (cod. 82259LP).

DILUTION PERCENTAGE OF CLEANPASS FLUIDO AG

ANTIFREEZE - ETHYLENE GLYCOL [%] VOLUME	TEMPERATURE FREEZING POINT [°C]
20	-7.5
30	-13
35	-18
40	-22.5
45	-28
50	-33.5
55	-42
60	-50

RECOMMENDED MINIMUM PERCENTAGE OF GLYCOL : 20 %

1.1.14. GAS CONNECTION

**DANGER**

In order to connect the gas connector of the boiler to the supply pipe use a stop seal of an appropriate size and material. The use of hemp, teflon tape or similar materials is strictly forbidden.

BEFORE PERFORMING THE GAS CONNECTION, MAKE SURE THAT:

- › the gas adduction line complies with the standards and regulations in force;
- › the tubing's section suits the requested capacity and its length;
- › the tubing is equipped with all safety and control devices required by the standards in force;
- › the internal and external seals of the gas infeed plant are checked;
- › the device is suitable for use with the type of gas available by checking the boiler data plate (placed on the inner side of the front casing. If they do not match you must take the necessary measures to adapt the boiler to another type of gas (see chapter GAS TRANSFORMATION);
- › the gas supply pressure falls within the values indicated on the data plate.

1.1.15. ELECTRICAL CONNECTION

**DANGER**

The equipment is electrically safe only if it is properly connected to an efficient grounding system, performed in compliance with the safety standards in force. You should check this essential safety requirement. If in doubt, request an accurate check of the electrical system performed by qualified staff, as the manufacturer is not responsible for any damages caused by lack of grounding system.

- › Make sure that the electrical systems is suitable for the maximum power absorbed by the equipment, value indicated on the data plate.
- › make sure that the cables section is appropriate for the maximum power absorbed by the equipment and that it is however not lower than 1 mm².
- › The equipment works with alternating current of 230 V and 50 Hz. The electrical connection must be performed using an all-pole switch with an opening of at least 3 millimetres between contacts placed upstream from the device.

**WARNING**

Make sure that the phase and neutral cables connection is performed in compliance with the wiring diagram (see chapter POWER SUPPLY).

**WARNING**

It is strictly forbidden the use of adaptors, multiple plugs and/or extensions for the general power supply of the equipment from the electrical network.

1.1.16. POWER SUPPLY

To power the boiler connect the electrical cables to the terminal inside the control panel as follows:



DANGER

Cut off the voltage from the main switch.

- › remove the boiler's front casing (refer to chapter ACCESSING THE BOILER).
- › loosen the two screws and remove the plate "A" (see fig. 1).
- › after removing the plate, connect the electrical cables to terminal "B" (see fig. 1):
 - the yellow/green cable to the terminal marked with grounding symbol "⊕".
 - the blue cable to the terminal marked with "N".
 - the brown cable to the terminal marked with "L".

After performing these operations, remount plate "A" and the front casing.

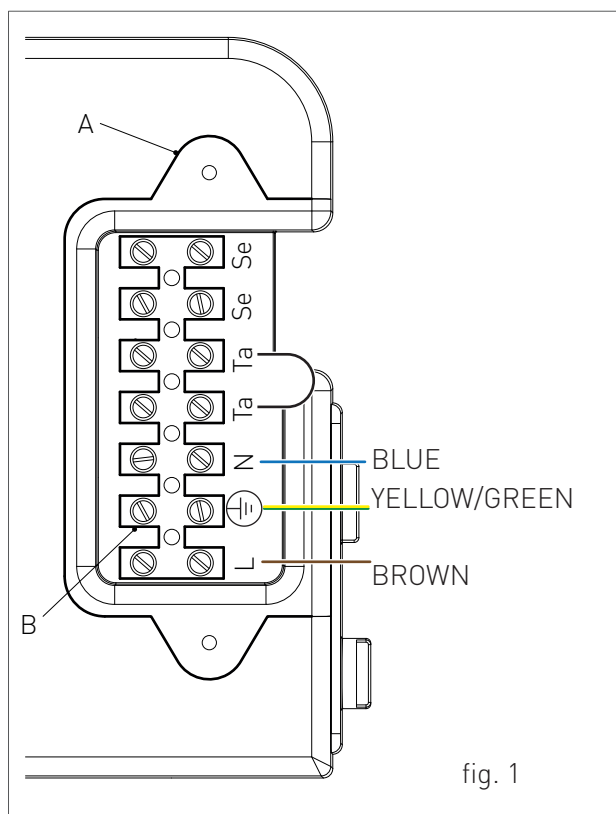

1.1.17. OPTIONAL ELECTRICAL CONNECTIONS

The cables should be inserted inside the boiler using the cable glands 'P1' and 'P2' placed under the board (see fig. 1). Make a hole on the cable gland, smaller than the cable diameter, to make sure that the air cannot pass through.

To wire the optionals below:

- **(SE) EXTERNAL TEMPERATURE PROBE COD. 73518LA**
- **(TA) ENVIRONMENT THERMOSTAT**
- **(CR) REMOTE CONTROL OPEN THERM COD. 40-00017**

use the terminal placed inside the control panel as follows:





DANGER

Cut off the voltage from the main switch.

- › remove the front casing of the boiler (see chapter ACCESSING THE BOILER); unscrew the screws and remove plate "A" (see fig. 2).
- › After removing the plate, connect the electrical cables to terminal "B" (see fig. 2):
 - For the external temperature Probe connect the two non-polarized conductors to the Se-Se contacts.
 - For the environment Thermostat or Remote control, first remove the bridge on the Ta-Ta contacts and then connect the two non-polarized conductors to the Ta-Ta contacts.

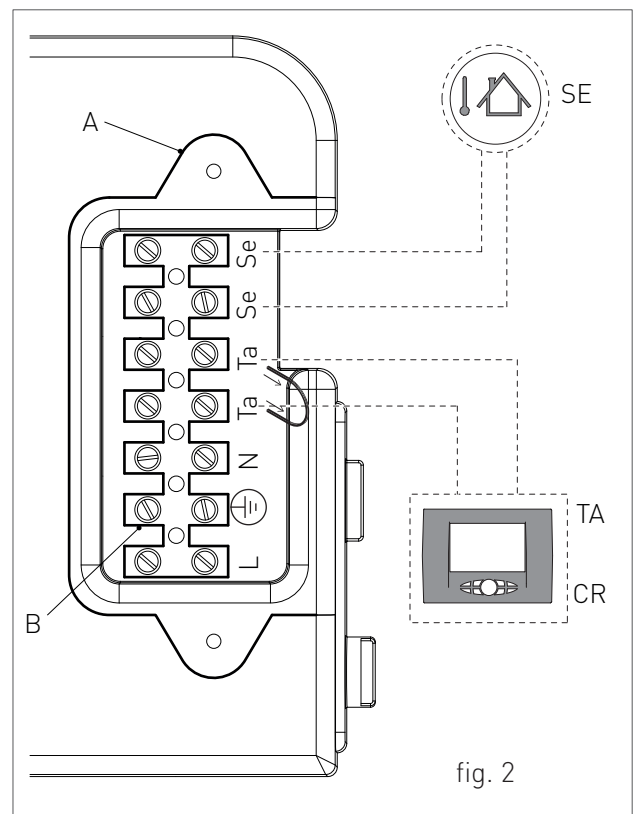
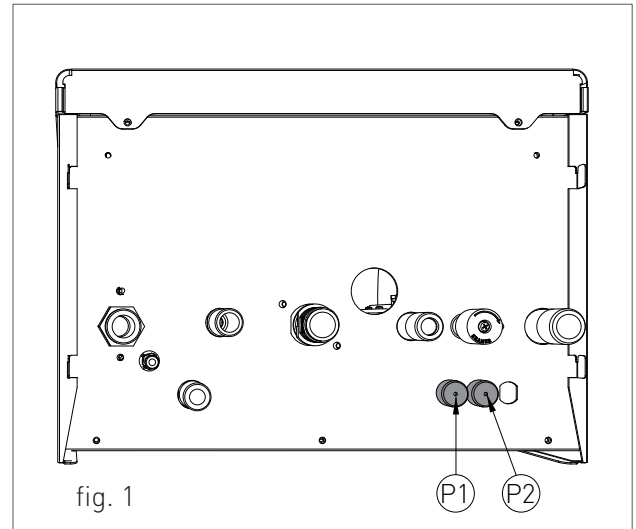
After performing these operations, remount plate "A" and the front casing.



NB: In case of simultaneous presence of external probe and remote control, the modulation board only sends the external temperature value to the remote device without using it for modulation. The communication between board and remote control takes place independently from the boiler's operating mode and after establishing the connection, the used interface on the board is disabled and the display shows the symbol .



To wire the optionals below:

- (PM) MODULATING PUMP
- (TP) DOMESTIC HOT WATER PRE-HEATING DEACTIVATION TIMER
- (CT) TELEPHONE DIALER
- BUS 0-10V
- (SVZ) CONTROL BOARD FOR AREA VALVES CONNECTED TO A REMOTE CONTROL COD. 65-00030

! DANGER
Cut off the voltage from the main switch.

- > remove the boiler's front casing (refer to chapter ACCESSING THE BOILER).
- > remove the crankcase of the control panel (see chapter ACCESSING THE ELECTRONIC BOARD).
- > after removing the crankcase, connect the items below to the electronic board (see fig. 1):

After performing these operations, remount the crankcase and the front casing.

use the electronic board placed inside the control panel as follows:

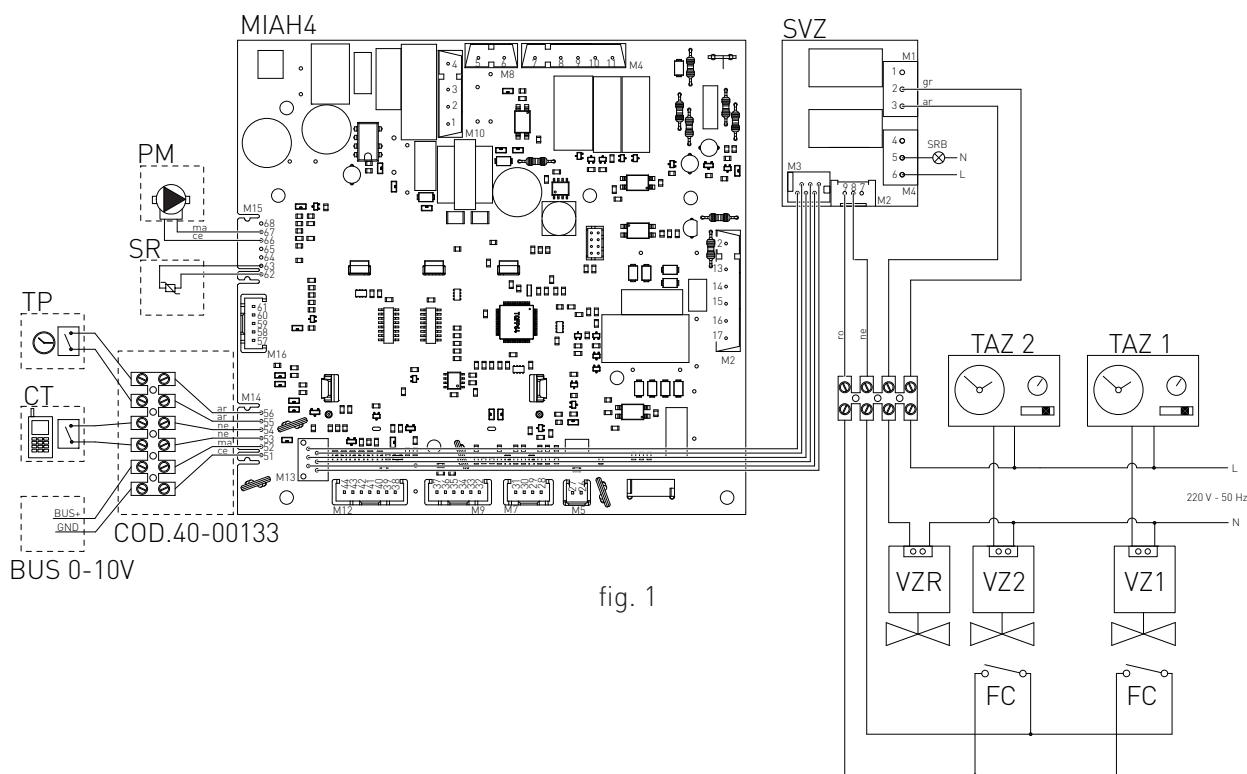

fig. 1

SR:	RETURN PROBE	FC:	AREA VALVES LIMIT SWITCH
SRB:	REMOTE LED FOR SIGNALLING BOILER BLOCK	GR:	GREY
TAZ1:	ENVIRONMENT THERMOSTAT AREA 1	AR:	ORANGE
TAZ2:	ENVIRONMENT THERMOSTAT AREA 2	NE:	BLACK
VZ1:	AREA 1 VALVE	MA:	BROWN
VZ2:	AREA 2 VALVE	CE:	LIGHT BLUE
VZR:	REMOTE CONTROLLED AREA VALVE	RO:	RED

1.1.18. FUME EXHAUST FITTINGS



WARNING

In order to ensure proper operation and efficiency of the device you have to connect the boiler fume exhaust fitting to the fume exhaust duct using appropriate polypropylene flue fittings for condensing boilers. It is recommended to install discharge systems approved by Radiant.

› Suction and discharge systems, tailored to individual installations, must be protected with accessories that prevent the ingress of foreign objects and atmospheric agents.

› For all discharge ducts, with regard to the fumes path, you should provide an uphill slope (outwards) so as to favour the reflux of the condensate towards the combustion chamber, suitably realized to collect and drain acid condensate.

› In order to discharge the fumes through a fumes exhaust duct carefully follow the technical standards in force.

INSTALLATION REQUIREMENTS

For Australia – refer to AS/NZS 5601 and local authority for minimum clearances as illustrated below:

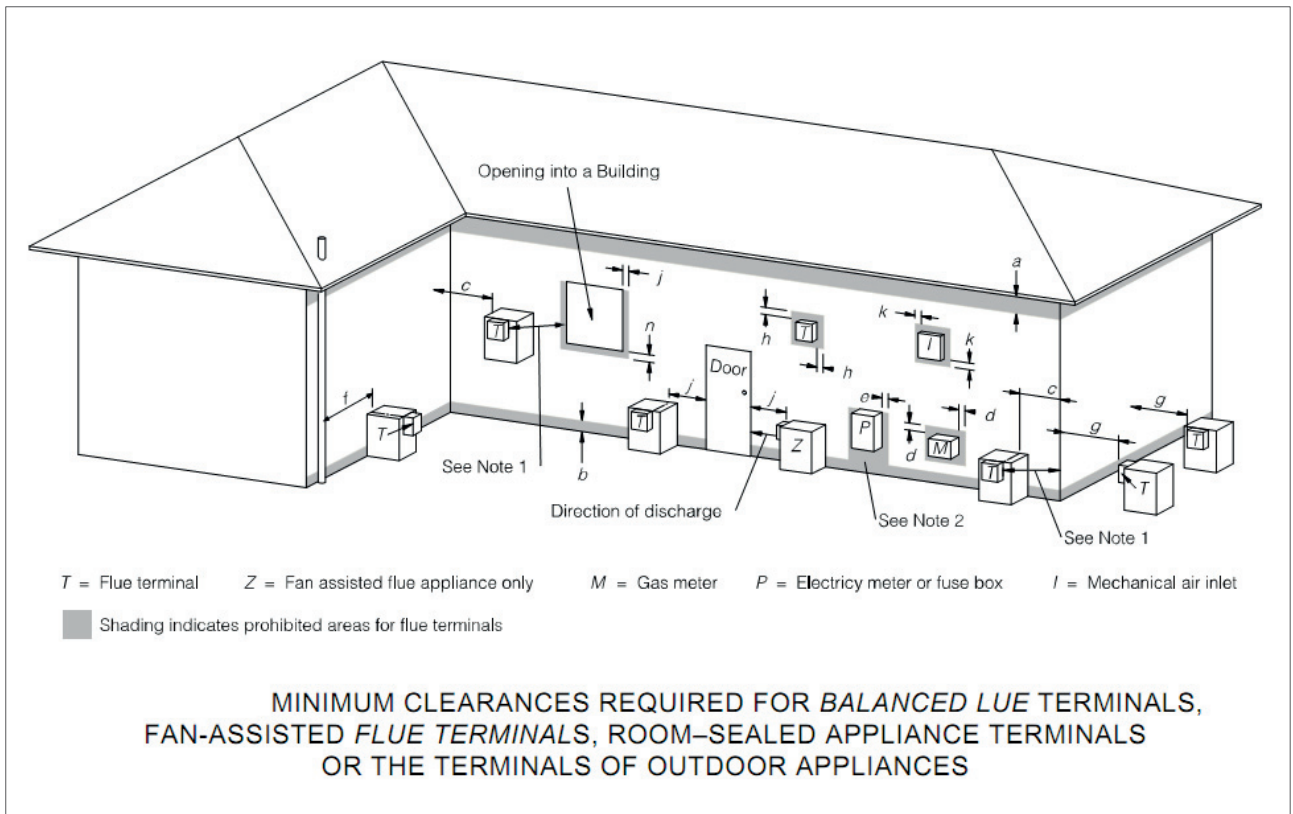



Ref.	Item	Minimum clearances mm	
		Natural draught	Fan assisted
a	Below eaves, balconies and other projections:		
	Appliances up to 50 MJ/h input	300	200
	Appliances over 50 MJ/h input	500	300
b	From the ground, above a balcony or other surface *	300	300
c	From a return wall or external corner *	500	300
d	From a <i>gas meter</i> (M) (see Note 5) (see Clause 5.11.5.9 for vent terminal location of regulator) (see Table 6.7 for New Zealand requirements)	1 000	1 000
e	From an electricity meter or fuse box (P) [†] (see Note 5)	500	500
f	From a drain pipe or soil pipe	150	75
g	Horizontally from any building structure * or obstruction facing a terminal	500	500
h	From any other <i>flue terminal</i> , cowl, or combustion air intake *	500	300
j	Horizontally from an openable window, door, non-mechanical air inlet, or any other opening into a building with the exception of sub-floor ventilation:		
	Appliances up to 150 MJ/h input*	500	300
	Appliances over 150 MJ/h input up to 200 MJ/h input*	1 500	300
	Appliances over 200 MJ/h input up to 250 MJ/h input*	1 500	500
	Appliances over 250 MJ/h input*	1 500	1 500
	All fan-assisted <i>flue appliances</i> , in the direction of discharge	—	1 500
k	From a mechanical air inlet, including a spa blower	1 500	1 000
n	Vertically below an openable window, non-mechanical air inlet, or any other opening into a building with the exception of sub-floor ventilation:		
	Space heaters up to 50 MJ/h input	150	150
	Other <i>appliances</i> up to 50 MJ/h input	500	500
	Appliances over 50 MJ/h input and up to 150 MJ/h input	1 000	1 000
	Appliances over 150 MJ/h input	1 500	1 500

* Unless *appliance* is certified for closer installation.

[†] Prohibited area below electricity meter or fuse box extends to ground level.

NOTES:

- Where dimensions *c*, *j* or *k* cannot be achieved an equivalent horizontal distance measured diagonally from the nearest discharge point of the terminal to the opening may be deemed by the *Technical Regulator* to comply.
- See Clause 6.9.4 for restrictions on a *flue terminal* under a covered area.
- See Figure J3 for clearances required from a *flue terminal* to an LP Gas cylinder. A *flue terminal* is considered to be a source of ignition.
- For *appliances* not addressed above acceptance should be obtained from the *Technical Regulator*.
- Minimum clearances *d* and *e* also apply to any combustion air intake openings of appliances.

1.1.19. TYPES OF FUME EXHAUST SYSTEMS

KIT RAIN - Ø 80 HORIZONTAL POLYPROPYLENE PIPE. OUTSIDE INSTALLATION

It allows the flue discharge through the exhaust pipe and the air intake from the environment.

Suitable only for condensing boilers.

It allows the combustion flues discharge through a polypropylene pipe and the air exhaust directly from the hole situated on the room sealed chamber plate protected by a metal net.

PLEASE SEE THE MAXIMUM DISCHARGE LENGTH IN THE TABLE IN CHAPTER "TECHNICAL DATA".

The maximum discharge length (or linear reference length) can be calculated summing the length of the linear tube and that equivalent to each additional curve with respect to the first.

Subsequent addition of a curve is similar to adding a linear length of tube according to the indications below:

co-axial curve Ø80 to 90° = 1.5 m

co-axial curve Ø80 to 45° = 0.8 m

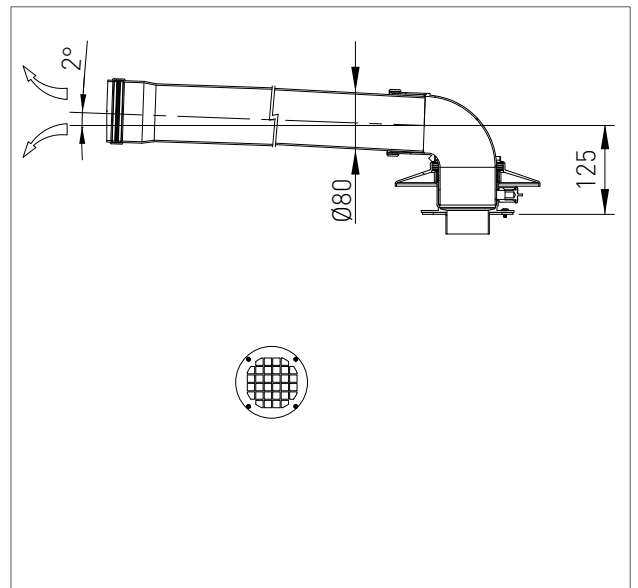
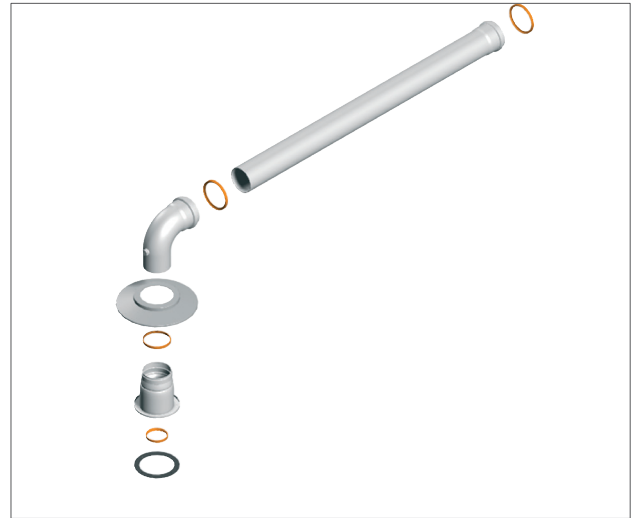



KIT RAIN L – Ø 80 VERTICAL POLYPROPYLENE PIPE. OUTSIDE INSTALLATION

It allows the flue discharge from the roof e and the air input from the environment.

Suitable only for condensing boilers.

It allows the combustion flues discharge through a polypropylene pipe and the air exhaust directly from the hole situated on the room sealed chamber plate protected by a metal net.

PLEASE SEE THE MAXIMUM DISCHARGE LENGTH IN THE TABLE IN CHAPTER “TECHNICAL DATA”.

The maximum discharge length (or linear reference length) can be calculated summing the length of the linear tube and that equivalent to each additional curve with respect to the first.

Subsequent addition of a curve is similar to adding a linear length of tube according to the indications below:

co-axial curve Ø80 to 90° = 1.5 m

co-axial curve Ø80 to 45° = 0.8 m

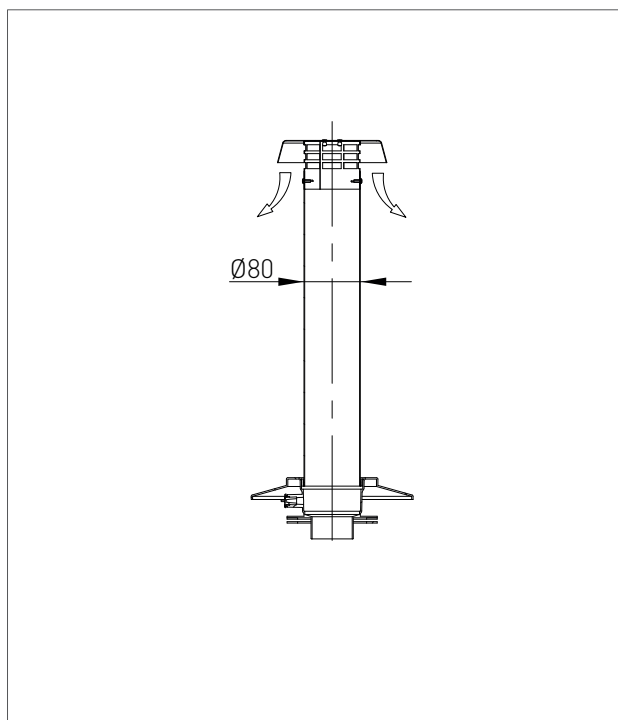
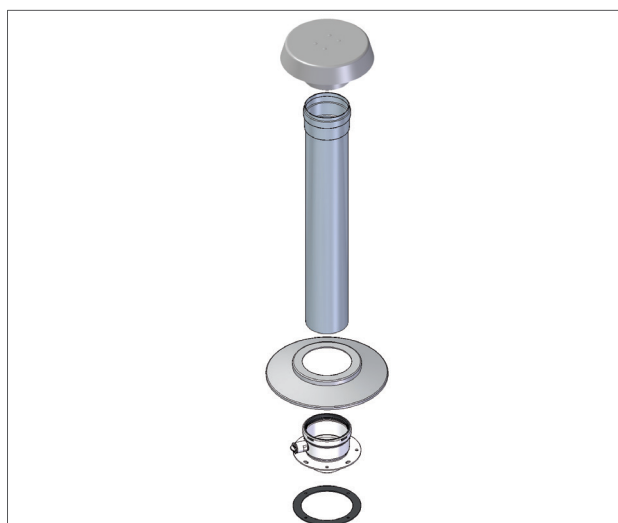



1. INSTALLATION

INSTALLER

FRONTAL FLUE KIT FOR RAIN SERIES - Ø 80 POLYPROPYLENE HORIZONTAL PIPE FOR OUTDOOR INSTALLATIONS WITHOUT FLUE CHIMNEY.

Suitable only for condensing boilers.

It allows the outside combustion flues discharge through a polypropylene pipe, and the air intake directly from the hole which is situated on the room sealed chamber plate, which is protected by a wire mesh.

PLEASE NOTE: during the flue analysis tests, place the analyser inside the frontal flue kit terminal slots.

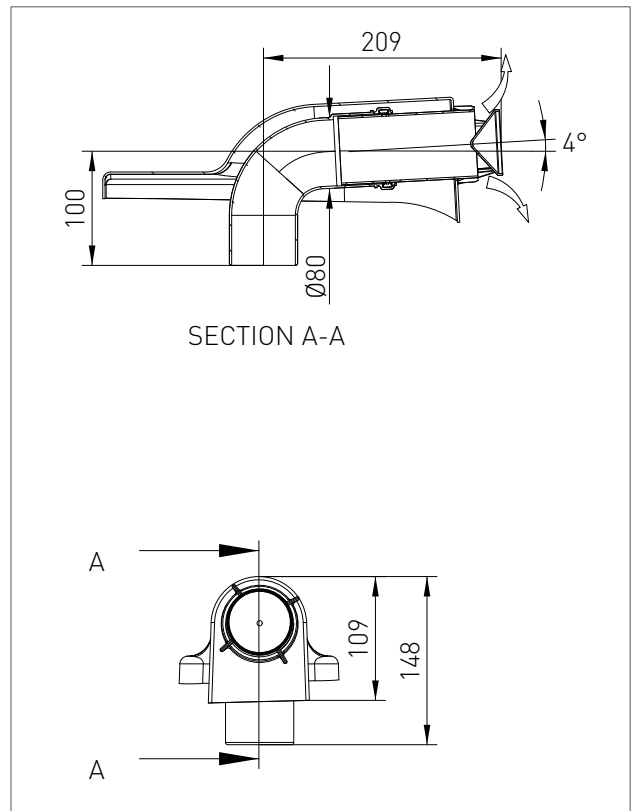



2. SUPPORT CENTRE SECTION

All operations described below relative to first start-up, maintenance and replacement should be performed only by qualified personnel and authorized by RADIANT BRUCIATORI S.p.A.

Gas leakage and operation of the appliance must be tested by the installer before leaving. When satisfied with the operation, please instruct the consumer on the correct method of operation.



2.1. FIRST START-UP

2.1.1. PRELIMINARY OPERATIONS FOR FIRST START-UP

The first start-up operations consist in checking the correct installation, adjustment and operation of the device. Proceed as follows:

- › check the inner system sealing in accordance with the indications provided by standard and regulations in force;
- › check if the gas used is suitable for the boiler;
- › check if the gas capacity and relative pressures comply with those on the plate;
- › check the intervention of the safety device in case of lack of gas;
- › make sure that the device supply voltage corresponds with that on the plate (230 V – 50 Hz) and that the wiring is correct;
- › make sure that the grounding system works properly;
- › make sure that the combustion air adduction and fumes and condensate discharge take place properly in compliance with the Local and National Laws and Standards in force;
- › make sure that the fumes discharge tube and its connection to the fume exhaust duct comply with the requirements of the Local and National Laws and Standards;
- › make sure that the heating system gate valves are open;
- › make sure that there is no intake of gaseous products within the system;
- › make sure that there are no flammable liquids or materials near the device;
- › open the boiler gas tap and make sure that there are no gas leaks upstream from the device (the burner gas connection must be checked while the machine is running);
- › in case of new installation of the gas supply network, the air inside the tubes may block the device at its first start-up. You might have to repeat the start-up procedure to purge all the air inside the tube.



2.1.2. BOILER COMMISSIONING





WARNING

Make sure that the system is correctly filled.

Proceed with boiler commissioning as follows:

- › Power the boiler.

THE START-UP SYSTEM WILL AUTOMATICALLY ACTIVATE THE SYSTEM AIR RELIEF CYCLE FUNCTION DISPLAYED ON SCREEN WITH CODE "F33" (ONLY AT FIRST START-UP WILL LAST FOR 5 MINUTES*). When function "F33" is active, the pump is enabled and the burner start-up request is disabled. The boiler can work normally only after completing the operation.

- › Open the gas tap.
- › Use the button  to select the desired operation mode. If the symbol is displayed fixed, it means that the function was activated.
- › The burner will start as soon as the thermostat contact is closed;
- › if the flame is missing the board will repeat the start-up operations after post-ventilation (20 seconds).
- › You might have to repeat the start-up operation several times to release all air inside the gas tube. Before repeating the operation, wait at least 5 seconds from the last start-up attempt and unlock the boiler from "E01" error code by pressing the Reset  key.

(* Only at the first start-up the system relief cycle performed by the boiler lasts 5 minutes. After each water pressure reset the boiler will automatically perform a reduces system relief cycle, of 2 minutes. Throughout this function the display will show the code "F33". The boiler can work normally only after completing the operation.

2.1.3. CO₂ VALUE CHECK AND CALIBRATION



WARNING

The CO₂ value should be checked with the casing assembled, while the gas valve should be adjusted with the casing open.

To check and calibrate the CO₂ value to minimum and maximum heating power proceed as follows:

FOR MINIMUM HEATING POWER

- › Activate the chimney sweeper function (F07) by keeping pressed the key 'R' for 7 seconds (the maximum time of this function is 15 minutes).
- › Insert the fumes analyser probe in the suitable 'PF' fumes inlet (fig. 1), then make sure that the CO₂ value complies with the requirements indicated in chapter "Technical data", otherwise unscrew the protection screw 'A' (fig. 2) and adjust using a 4 Allen wrench the screw '2' (fig. 2) of the Off-Set adjuster. To increase the CO₂ value, turn the screw clockwise and vice-versa if you want to decrease it. Once completed the adjustment, tighten the protection screw 'A' (fig. 2) on the Off-Set adjuster.

FOR MAXIMUM HEATING POWER

- › Press the key '+' of the heating temperature setting , to adjust the maximum heating power.
- › Make sure that the CO₂ value complies with the indications in "Technical data", otherwise adjust using screw '1' (fig. 2) of the gas flow adjuster. To increase the CO₂ value, turn the screw anti-clockwise and vice-versa if you want to decrease it.
- › After each adjustment variation on screw '1' (fig. 2) of the gas flow adjuster you have to wait for the boiler to stabilize itself to the set value (about 30 seconds).



- › Press the key '-' of the heating temperature setting  and make sure that the CO₂ value did not change to minimum, if changed repeat the calibration described in the previous paragraph.
- › Deactivate the chimney sweeper function by selecting the OFF mode by using the key .

fig. 1

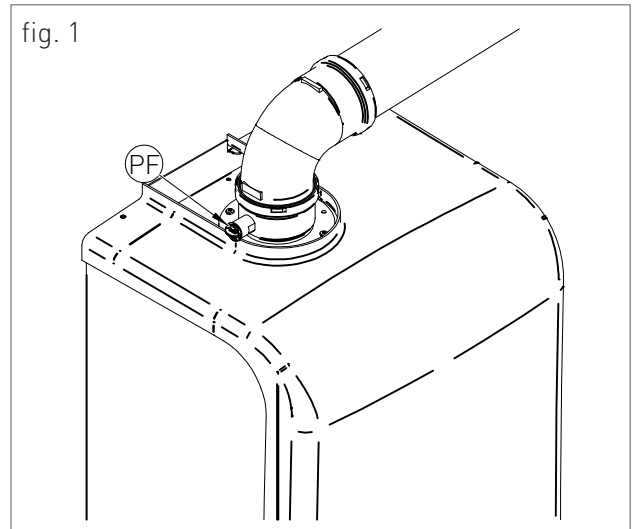
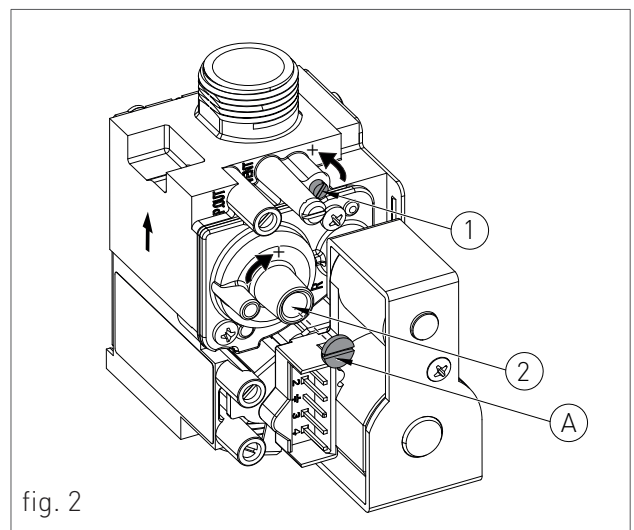

fig. 2





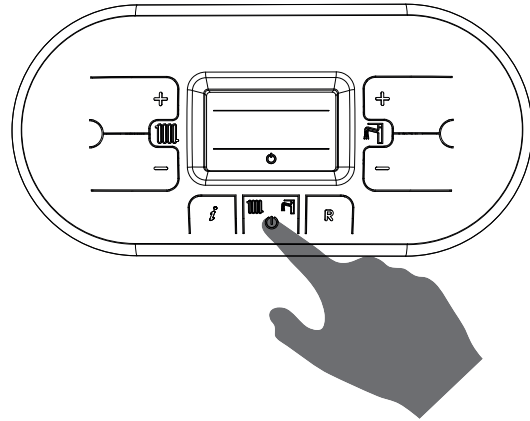

2.1.4. ACCESSING AND PROGRAMMING THE PARAMETERS

To access the parameters menu and adjust their values, follow the procedure below:

1. Press the button  to select the OFF mode displayed using the symbol .



2. Hold at the same time the keys  and  until on the display appears the symbol  with the message 'P00', and release the keys  and .

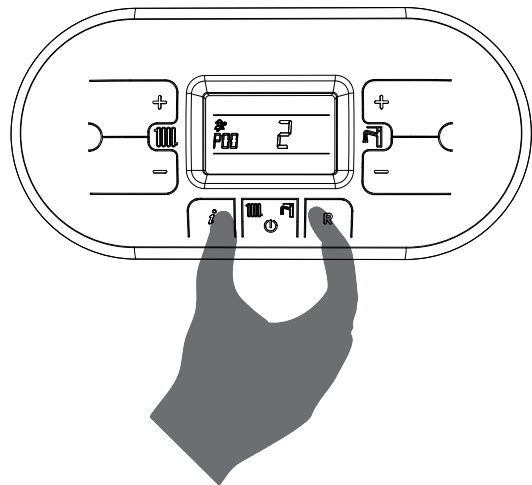

3. Use the keys  and  of the heating circuit  to select the parameter to be edited.

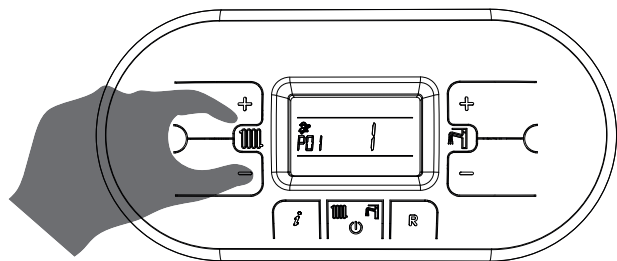

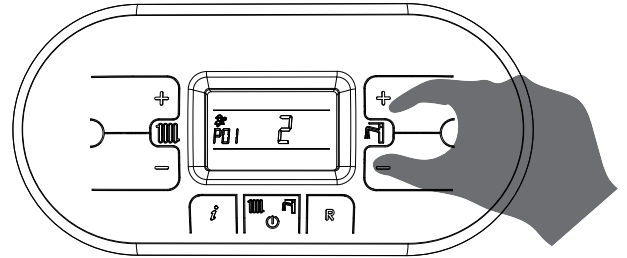

4. Use the keys '+' and '-' of the domestic circuit  to change the value of the parameter.

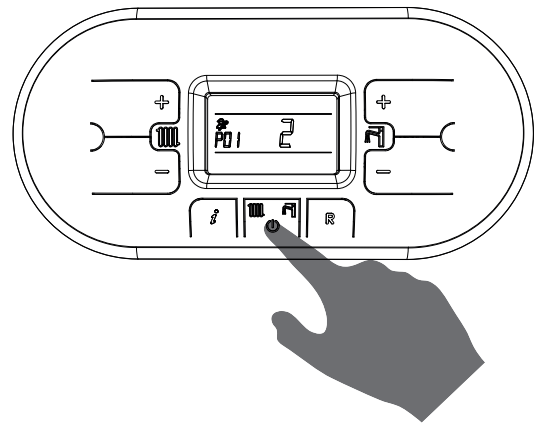

5. Press the key  to confirm the action and wait for the display to stop blinking, indication of the fact that the adjustment was implemented.



6. To exit the parameters menu, hold at the same time the keys  and  and wait for the symbol  to appear on the display.

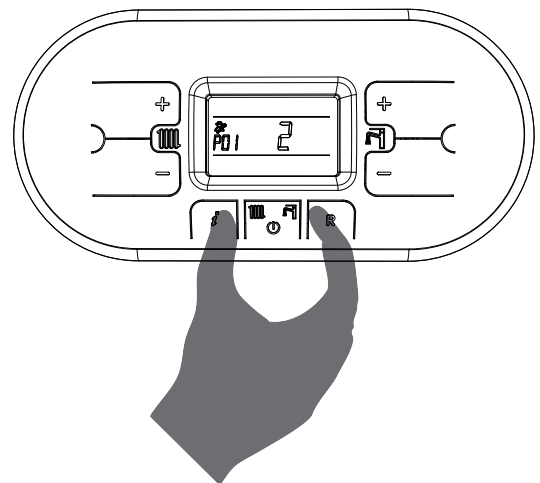



2.1.5. DIGITECH CS PARAMETERS TABLE

PARAMETER	DESCRIPTION	RANGE	FUNCTION
P00	BOILER MODEL SELECTION	0 - 10	0 = 13 KW
			1 = 18 KW (HEAT.) / 24 KW (DOMESTIC)
			2 = 25 KW
			3 = 28 KW
			4 = 34 KW
			5 = 55 KW
			6 = 100 KW
			7 = R1K 18_24-R2K 24-R2KA 24 (IN ALL VERSIONS)
			8 = R1K 25_28-R2K 28-R2KA 28 (IN ALL VERSIONS)
			9 = R1K 34-R2K 34-R2KA 34 (IN ALL VERSIONS)
10 = R1K 50			
P01	BOILER TYPE SELECTION	0 - 5	0 = INSTANTANEOUS R2K
			1 = INSTANTANEOUS RKR
			2 = ACCUMULATION
			3 = ACCUMULATION COMFORT
			4 = INSTANTANEOUS COMFORT - FAST H2O
5 = HEATING ONLY			



2. FIRST START-UP

PARAMETER	DESCRIPTION	RANGE	FUNCTION
P02	<p>GAS TYPE SELECTION</p> <p>ATTENTION: READ THE INSTRUCTION IN CHAPTER 'GAS TRANSFORMATION' BEFORE CHANGING THIS PARAMETER.</p>	0 - 1	<p>0 = METHANE</p> <hr/> <p>1 = LPG</p>
P03	<p>SETTING THE HEATING TEMPERATURE</p> <p>IN CASE THE BOILER IS INSTALLED AS PART OF A LOW TEMPERATURE CIRCUIT, PLEASE INSTALL A SAFETY THERMOSTAT ON THE HEATING FLOW, WHICH CAN STOP THE BOILER ACTIVITY IN CASE OF HIGH HEATING FLOW TEMPERATURE. THE COMPANY ASSUMES NO LIABILITY FOR DAMAGE CAUSED TO PERSONS OR FOR FAILURE TO COMPLY WITH THESE INSTRUCTIONS.</p>	0 - 1	<p>0 = STANDARD (30-80 °C) (SET BY DEFAULT)</p> <hr/> <p>1 = REDUCED (25-45 °C) FOR FLOOR SYSTEMS</p>
P04	<p>HEATING RUN-UP</p> <p>THROUGH THIS PARAMETER YOU CAN SET THE TIME, DURING START-UP PHASE, NECESSARY FOR THE BOILER TO REACH THE MAXIMUM SET POWER (ON THE HEATING SIDE).</p>	0 - 4	<p>0 = (DISABLED)</p> <hr/> <p>1 = 50 SECONDS</p> <hr/> <p>2 = 100 SECONDS</p> <hr/> <p>3 = 200 SECONDS (SET BY DEFAULT)</p> <hr/> <p>4 = 400 SECONDS</p>
P05	<p>ANTI-WATER HAMMER SELECTION</p> <p>ONCE THIS FUNCTION IS ENABLED, THE DHW CONTACT WILL BE DELAYED FOR A TIME EQUAL TO THE SET VALUE.</p>	0 - 20	<p>0 = DISABLED</p> <hr/> <p>1 - 20 = THE VALUE IS EXPRESSED IN SECONDS</p>
P06	<p>DOMESTIC CIRCUIT PRESERVATION FUNCTION (ONLY FOR INSTANTANEOUS BOILERS)</p> <p>THROUGH THIS PARAMETER YOU CAN PRESERVE THE CIRCULATOR THE DIVERTER VALVE IN DOMESTIC POSITION FOR A PERIOD OF TIME EQUAL TO THE POST-CIRCULATION (SEE PARAMETER P09), SO AS TO MAINTAIN THE SECONDARY EXCHANGER HOT.</p>	0 - 1	<p>0 = DISABLED (SET BY DEFAULT)</p> <hr/> <p>1 = ENABLED</p>
P07	<p>HEATING TIMING</p> <p>THROUGH THIS PARAMETER YOU CAN SET THE MINIMUM TIME FOR WHICH THE BURNER WILL BE TURNED OFF ONCE THE HEATING TEMPERATURE REACHED THE USER SET TEMPERATURE.</p>	0 - 90	<p>VALUE EXPRESSED IN MULTIPLES OF 5 SECONDS (PRE-SET AT 36 X 5 = 180 SECONDS)</p>



PARAMETER	DESCRIPTION	RANGE	FUNCTION
P08	POST-CIRCULATION HEATING TIMING THROUGH THIS PARAMETER, IT IS POSSIBLE TO SET THE OPERATION TIME OF THE PUMP AFTER THE MAIN BURNER TURNS OFF DUE TO THE ENVIRONMENT THERMOSTAT.	0 - 90	VALUE EXPRESSED IN MULTIPLES OF 5 SECONDS (PRE-SET AT 36 X 5 = 180 SECONDS)
P09	POST-CIRCULATION DOMESTIC / STORAGE TIMING THROUGH THIS PARAMETER, IT IS POSSIBLE TO SET THE OPERATION TIME OF THE PUMP AFTER CLOSING THE TAP OR REACHING THE TEMPERATURE SET IN THE BOILER.	0 - 90	VALUE EXPRESSED IN MULTIPLES OF 5 SECONDS (PRE-SET AT 24 X 5 = 120 SECONDS)
P10	DOMESTIC FAN MINIMUM SPEED ADJUSTMENT THROUGH THIS PARAMETER YOU CAN SET THE FAN MINIMUM SPEED IN DOMESTIC PHASE, THAT CORRESPONDS TO THE MINIMUM BURNER POWER DURING A REQUEST TO OPERATE IN DOMESTIC MODE. THE VALUE IS PRE-SET BASED ON THE SET POWER (SEE PARAMETER P00) AND ON THE GAS TYPE (SEE PARAMETER P02)	45 - VALUE SET FOR PARAMETER P11	THE VALUE IS EXPRESSED IN HERTZ (1HZ = 30 RPM)
P11	DOMESTIC FAN MAXIMUM SPEED ADJUSTMENT THROUGH THIS PARAMETER YOU CAN SET THE FAN MAXIMUM SPEED IN DOMESTIC PHASE, THAT CORRESPONDS TO THE MAXIMUM BURNER POWER DURING A REQUEST TO OPERATE IN DOMESTIC MODE. THE VALUE IS PRE-SET BASED ON THE SET POWER (SEE PARAMETER P00) AND ON THE GAS TYPE (SEE PARAMETER P02)	VALUE SET FOR PARAMETER P10 - 203	THE VALUE IS EXPRESSED IN HERTZ (1HZ = 30 RPM)
P12	HEATING FAN MINIMUM SPEED ADJUSTMENT THROUGH THIS PARAMETER YOU CAN SET THE FAN MINIMUM SPEED IN HEATING PHASE, THAT CORRESPONDS TO THE MINIMUM BURNER POWER DURING A REQUEST TO OPERATE IN HEATING MODE. [SEE CHAPTER 'HEAT CAPACITY DIAGRAM (KW) - ELECTRIC FAN FREQUENCY (HZ)']. THE VALUE IS PRE-SET BASED ON THE SET POWER (SEE PARAMETER P00) AND ON THE GAS TYPE (SEE PARAMETER P02)	45 - VALUE SET FOR PARAMETER P13	THE VALUE IS EXPRESSED IN HERTZ (1HZ = 30 RPM)



2. FIRST START-UP

PARAMETER	DESCRIPTION	RANGE	FUNCTION
P13	<p>HEATING FAN MAXIMUM SPEED ADJUSTMENT</p> <p>THROUGH THIS PARAMETER YOU CAN SET THE FAN MAXIMUM SPEED IN HEATING PHASE, THAT CORRESPONDS TO THE MAXIMUM BURNER POWER DURING A REQUEST TO OPERATE IN HEATING MODE [SEE CHAPTER 'HEAT CAPACITY DIAGRAM (KW) -ELECTRIC FAN FREQUENCY (HZ)'].</p> <p>THE VALUE IS PRE-SET BASED ON THE SET POWER (SEE PARAMETER P00) AND ON THE GAS TYPE (SEE PARAMETER P02)</p>	<p>VALUE</p> <p>SET FOR</p> <p>PARAMETER</p> <p>P12 - 203</p>	<p>THE VALUE IS EXPRESSED</p> <p>IN HERTZ</p> <p>(1HZ = 30 RPM)</p>
P14	<p>STARTING STEP ADJUSTMENT</p> <p>THROUGH THIS PARAMETER YOU CAN SET THE FAN SPEED DURING START-UP</p> <p>THE VALUE IS PRE-SET BASED ON THE SET POWER (SEE PARAMETER P00) AND ON THE GAS TYPE (SEE PARAMETER P02)</p>	<p>VALUE</p> <p>SET FOR</p> <p>PARAMETER</p> <p>P10 - 203</p>	<p>THE VALUE IS EXPRESSED</p> <p>IN HERTZ</p> <p>(1HZ = 30 RPM)</p>
P15	<p>ANTI-LEGIONELLA FUNCTION</p> <p>(FOR STORAGE BOILERS ONLY)</p> <p>THROUGH THIS PARAMETER YOU CAN ACTIVATE/DEACTIVATE THE "ANTILEGIONELLA" HEAT TREATMENT OF THE STORAGE TANK. EVERY 7 DAYS THE WATER TEMPERATURE INSIDE THE STORAGE IS HEATED BEYOND 60 °C THUS GENERATING A BURNING HAZARD. KEEP UNDER CONTROL SUCH DOMESTIC HOT WATER TREATMENT (AND INFORM THE USERS) TO AVOID UNFORSEEABLE DAMAGES TO PERSONS, ANIMALS AND PROPERTY. A THERMOSTATIC VALVE SHOULD BE INSTALLED AT THE DOMESTIC HOT WATER OUTLET TO AVOID ANY BURNS.</p>	<p>0 - 1</p>	<p>0 = DISABLED</p> <hr/> <p>1 = ENABLED (PRE-SET BY DEFAULT ON STORAGE BOILERS ONLY)</p>



PARAMETER	DESCRIPTION	RANGE	FUNCTION
P16	<p>CLIMATE COMPENSATION CURVE (ONLY WITH EXTERNAL PROBE CONNECTED)</p> <p>YOU CAN CONNECT AN EXTERNAL TEMPERATURE PROBE (SEE CHAPTER 'ELECTRICAL CONNECTIONS') THAT AUTOMATICALLY CHANGES THE DELIVERY TEMPERATURE BASED ON THE EXTERNAL MEASURED TEMPERATURE. THE NATURE OF THE CORRECTION DEPENDS ON THE THERMO-ADJUSTMENT VALUE KD SET (SEE CHART).</p> <p>THE SELECTION OF THE CURVE IS DETERMINED BY THE MAXIMUM DELIVERY TEMPERATURE T_m AND THE MINIMUM EXTERNAL TEMPERATURE T_e TAKING INTO ACCOUNT THE HOUSE INSULATION DEGREE.</p> <p>THE VALUES OF THE DELIVERY TEMPERATURES T_m, REFER TO STANDARD SYSTEMS 30-80 °C OR FLOOR SYSTEMS 25-45 °C. THE SYSTEM TYPE CAN BE SET FROM PARAMETER P03.</p>	0 - 30	(SET BY DEFAULT AT 25) THE NUMBERING OF THE VALUE CORRESPONDS TO 'KD' CURVES ON THE CHART (SEE CHART BELOW).

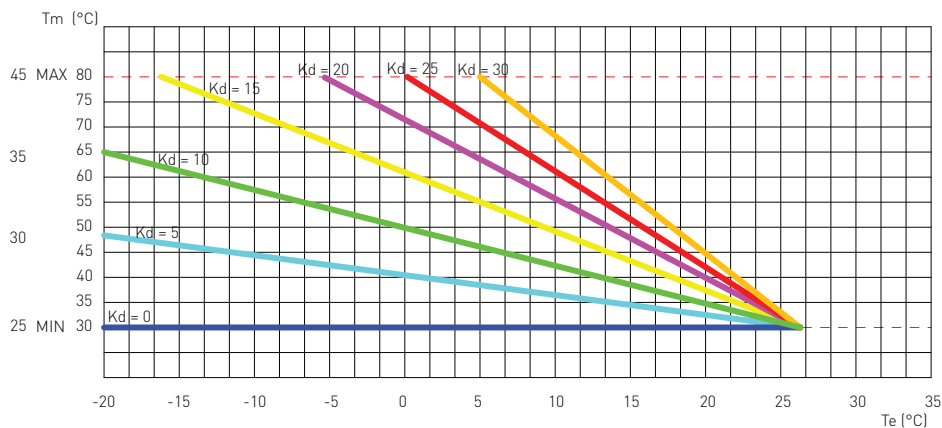

P17	<p>DISABLEMENT OF DOMESTIC HOT WATER LINE BY MEANS OF SWITCH (ONLY FOR FAST BOILERS)</p> <p>BY ENABLING THIS PARAMETER IN THE PRESENCE OF A CONNECTION (FOR EXAMPLE A BOILER CLOCK OR A TEMPERATURE THERMOSTAT) ON BOILER CLOCK SWITCH ON THE BOARD, THE REQUEST FOR BURNER IGNITION ON THE DOMESTIC HOT WATER LINE WILL BE DISABLED UPON BOILER CLOCK SWITCH CLOSURE.</p> <p>EXAMPLE 1: WITH THE BOILER CLOCK SWITCH OPEN, UPON THE REQUEST FOR DOMESTIC HOT WATER, THE FLOW SWITCH AND THE BOILER WILL TURN ON.</p> <p>EXAMPLE 2: WITH THE BOILER CLOCK SWITCH CLOSE, UPON THE REQUEST FOR DOMESTIC HOT WATER, THE FLOW SWITCH AND THE BOILER WILL NOT TURN ON.</p>	0 - 1	<p>0 = DISABLED (SET BY DEFAULT)</p> <p>1 = ENABLED</p>
-----	--	-------	---



2. FIRST START-UP

PARAMETER	DESCRIPTION	RANGE	FUNCTION
P18	ENABLING BUS INDUSTRIAL PILOTING 0 -10V THROUGH THIS PARAMETER YOU CAN ENABLE OR DISABLE THE BUS INDUSTRIAL INPUT 0-10 V TO SET THROUGH EXTERNAL BUS THE BURNER POWER OR THE DELIVERY TEMPERATURE.	0 - 2	0 = DISABLED (SET BY DEFAULT) 1 = TEMPERATURE CONTROL MODE 2 = POWER CONTROL MODE
P19	MINIMUM HEATING SETPOINT THROUGH THIS PARAMETER YOU CAN SET THE USER-ADJUSTABLE MINIMUM HEATING TEMPERATURE.	20 - 40	THE VALUE IS EXPRESSED IN °C
P20	MAXIMUM HEATING SETPOINT THROUGH THIS PARAMETER YOU CAN SET THE USER-ADJUSTABLE MAXIMUM HEATING TEMPERATURE.	40 - 90	THE VALUE IS EXPRESSED IN °C
P21	MAXIMUM DOMESTIC SETPOINT THROUGH THIS PARAMETER YOU CAN SET THE USER-ADJUSTABLE MAXIMUM DOMESTIC TEMPERATURE.	45 - 75	THE VALUE IS EXPRESSED IN °C
P22	SET POINT ΔT DELIVERY-RETURN (ONLY WITH MODULATING PUMP AND RETURN PROBE CONNECTED) THROUGH THIS PARAMETER YOU CAN SET THE TEMPERATURE DIFFERENCE BETWEEN DELIVERY AND RETURN.	0 10 - 40	0 = DISABLED THE VALUE IS EXPRESSED IN °C
P23	MODULATING PUMP MINIMUM SPEED (ONLY WITH MODULATING PUMP AND RETURN PROBE CONNECTED) THROUGH THIS PARAMETER YOU CAN SET THE MINIMUM SPEED VALUE OF THE MODULATING PUMP DURING A REQUEST TO OPERATE IN HEATING MODE.	50 - 70	THE VALUE IS EXPRESSED IN PERCENTAGE
P24	MODULATING PUMP MAXIMUM SPEED (ONLY WITH MODULATING PUMP AND RETURN PROBE CONNECTED) THROUGH THIS PARAMETER YOU CAN SET THE MAXIMUM SPEED VALUE OF THE MODULATING PUMP DURING A REQUEST TO OPERATE IN HEATING MODE.	70 - 100	THE VALUE IS EXPRESSED IN PERCENTAGE
P25	D.H.W STORAGE TANK TEMPERATURE SETPOINT (FOR STORAGE BOILERS ONLY) THROUGH THIS PARAMETER YOU CAN SET THE PRIORITY STARTING VALUE OF THE STORAGE TANK, COMPARED TO THE USER ADJUSTABLE D.H.W SETPOINT.	3 - 9	THE VALUE IS EXPRESSED IN °C (PRE-SET AT 9°C)



PARAMETER	DESCRIPTION	RANGE	FUNCTION
P26	MODBUS ADDRESS BY MEANS OF THIS PARAMETER, IT IS POSSIBLE TO SET THE ADDRESS OF THE BOARD ON MODBUS IN ORDER TO PERFORM A CASCADE SYSTEM.	1 - 16	BOILER NUMBERING FOR MODBUS
P27	MODBUS COMMUNICATION BAUD RATE BY MEANS OF THIS PARAMETER, IT IS POSSIBLE TO SELECT THE MODBUS COMMUNICATION BAUD RATE SUPPORTED BY THE SAME INTERFACE.	0 - 5	0 = 9600 1 = 1200 2 = 2400 3 = 4800 4 = 9600 5 = 19200
P28	MODBUS MODE	0 - 2	0 = ENABLED 1 = ENABLED WITH LOCAL SETTINGS 2 = DISABLED (SET BY DEFAULT)
P29	ΔT HEATING POSTCIRCULATION THROUGH THIS PARAMETER, IT IS POSSIBLE TO SET THE TEMPERATURE DIFFERENCE FROM THE MAIN BURNER SHUTOFF, FOR THE INTERVENTION OF THE ROOM THERMOSTAT, TO THE DISABLING OF THE PUMP IN HEATING MODE.	0 - 25	THE VALUE IS EXPRESSED IN °C (SET BY DEFAULT AT 10 °C)
P30	ΔT D.H.W./TANK POSTCIRCULATION THROUGH THIS PARAMETER, IT IS POSSIBLE TO SET THE TEMPERATURE DIFFERENCE FROM THE CLOSING OF THE TAP OR THE REACHING OF THE TEMPERATURE SET IN THE BOILER TO THE DISABLING OF THE PUMP IN HEATING MODE.	0 - 25	THE VALUE IS EXPRESSED IN °C (SET BY DEFAULT AT 10 °C)
P31	HEATING MODE ANTI-FREEZE TEMPERATURE SETTING THROUGH THIS PARAMETER, IT IS POSSIBLE TO SET THE HEATING WATER TEMPERATURE AT WHICH THE ANTI-FREEZE PROTECTION DEVICE STARTS WORKING.	5 - 12	THE VALUE IS EXPRESSED IN °C (SET BY DEFAULT AT 8 °C)



2. FIRST START-UP

PARAMETER	DESCRIPTION	RANGE	FUNCTION
P32	<p>ENABLING FLOWMETER (ONLY WITH FLOWMETER KIT CODE 65-00712 CONNECTED)</p> <p>THROUGH THIS PARAMETER IT IS POSSIBLE TO ENABLE THE FLOWMETER FOR MEASURING THE HEATING FLOW RATE AND MANAGE ACTIVATION OF THE BOILER BY THE FLOW RATE ITSELF.</p>		<p>0 = DISABLED (SET BY DEFAULT)</p> <hr/> <p>1 = ENABLED</p>
P33	<p>MINIMUM THRESHOLD TO ACTIVATE THE BOILER THROUGH THE FLOWMETER (ONLY IF PARAMETER P32 IS SET ON THE VALUE '1')</p> <p>THROUGH THIS PARAMETER IT IS POSSIBLE TO SET THE MINIMUM WATER FLOW RATE REQUIRED TO ACTIVATE THE BOILER.</p>	20 - 68	<p>VALUE EXPRESSED IN HERTZ</p> <p>20 Hz = 3.5 l/min 23 Hz = 4 l/min 28 Hz = 5 l/min 34 Hz = 6 l/min 39 Hz = 7 l/min 44 Hz = 8 l/min 50 Hz = 9 l/min 55 Hz = 10 l/min 61 Hz = 11 l/min 66 Hz = 12 l/min</p>



2.1.6. ELECTRIC FAN FREQUENCY/HEAT CAPACITY DIAGRAM

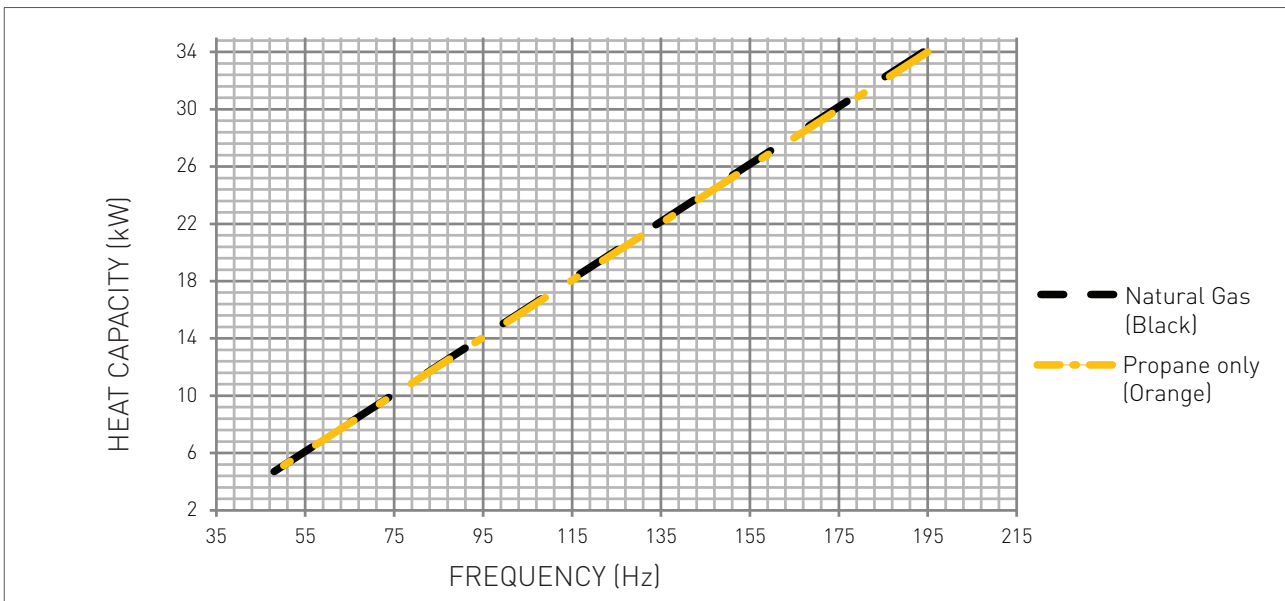

GAS TYPE		MINIMUM FREQUENCY	MAXIMUM FREQUENCY
Natural Gas (Black)	Hz	45	186
Universal LPG (Orange)	Hz	45	184

2.2. MAINTENANCE

2.2.7. GENERAL MAINTENANCE WARNINGS

**DANGER**

Before each components cleaning or replacement operation, ALWAYS cut off the POWER, WATER and GAS supply of the boiler.

**WARNING**

To ensure greater life span and proper operation of the device, during the maintenance operations use only original spare parts.

**ATTENTION**

To ensure the efficiency and safety of the device, the maintenance operations must be realized on an annual basis. The operations described below, are essential to the validity of the standard RADIANT warranty and must be performed by professionally qualified personnel in accordance with current legislation and authorized by RADIANT.

Please perform the following operations once a year:

- › check the integrity and the position of the sealed chamber sealing gasket;
 - › check the primary exchanger, if necessary, clean it;
 - › check the operation of the gas light up and safety systems. If necessary, remove and clean the flame detection and light up electrodes from incrustations paying attention to respect the distances with respect to the burner;
 - › check the heating circuit safety systems: limit temperature safety thermostat; limit pressure safety;
 - › check the pre-load pressure of the expansion vessel;
 - › make sure that the permanent ventilation outlets are present, correctly sized and functioning, based on the installed devices. Respect the requirements provided by Local and National legislation;
 - › periodically check the integrity of the fume exhaustion system for safety and proper operation;
 - › check that the wiring is performed in compliance with the requirements in the boiler instruction manual;
 - › check the wiring inside the control panel;
 - › check the flow and temperature of domestic hot water;
 - › check the proper operation of the condensate draining system, including the devices outside the boiler such as condensate collection devices installed along the path of the fume exhaust duct or neutralization devices for acid condensate.
- › Check that the system's water PH is between 6.5 and 8.5;
 - › check the sealing of the gas components, and replace if necessary the gaskets;
 - › check the sealing of the water components, and replace if necessary the gaskets;
 - › visually check the flame and the condition of the combustion chamber;
 - › if necessary make sure that the combustion is suitably adjusted and if required proceed as indicated in section "CO2 VALUE CHECK AND CALIBRATION";
 - › remove and clean the burner from oxidation;



- › check that the liquid flow is not obstructed and that there are no combustion gas refluxes inside the internal system.



2.2.8. TECHNICAL DATA

Model		R2K 34 RAIN
Maximum nominal heat capacity in heating circuit	MJ/h	135
Maximum nominal heat capacity in domestic circuit	MJ/h	135
Minimum nominal heat capacity in heating circuit	MJ/h	16
Minimum nominal heat capacity in domestic circuit	MJ/h	16
Useful thermal power - 60/80°C	kW	33,35
Minimum useful thermal power - 60/80°C	kW	3,94
Useful thermal power - 30/50°C	kW	36,19
Performance at 100% Pn - 60/80°C	%	98,08
Performance at 30% Pn - return 47°C	%	102,14
Performance at 30% Pn - return 30°C	%	108,57
Performance at 100% Pn - 30/50°C	%	106,43
Maximum combustion Performance	%	97,6
Fumes temperature at nominal heat capacity	°C	69,4
Fumes temperature at minimum heat capacity	°C	61,3
CO ₂ at nominal heat capacity - Natural Gas	%	9,45 - 9,25
CO ₂ at minimum heat capacity - Natural Gas	%	9,05 - 8,85
CO ₂ at nominal heat capacity - Universal LPG	%	10,55 - 10,35
CO ₂ at minimum heat capacity - Universal LPG	%	9,9 - 9,7
CO at nominal heat capacity	ppm	75
Fumes mass at nominal heat capacity	g/s	14,96
Fumes mass at minimum heat capacity	g/s	1,88
NO _x class	class	6
Weighted Nox (0% O ₂) mg/kWh	mg/kWh	55
Heating circuit		
Adjustable heating temperature	°C	30-80 / 25-45
Maximum operating water temperature for heating circuit	°C	95
Maximum operating pressure for heating circuit	kPa	300
Minimum operating pressure for heating circuit	kPa	30
Capacity of the system expansion vessel	litres	8
Domestic circuit		
Adjustable domestic temperature	°C	35-60
Maximum pressure for domestic circuit	kPa	600
Minimum pressure for domestic circuit	kPa	50
Specific capacity in continuous service - Δt 30°C	litres/min	16
Dimensional characteristics		
Width	mm	420
Depth	mm	370
Height	mm	787
Gross weight	Kg	44
Water connections		
Flow	Ø	3/4"
Cold water	Ø	1/2"
Hot water	Ø	1/2"
Gas	Ø	3/4"



Return	Ø	3/4"
Flue fittings		
Maximum electric fan pressure available	Pa	91
Minimum electric fan pressure available	Pa	5.8
Max discharge length Ø50 - Hor duct	m	2
Max discharge length Ø60 - Hor duct	m	12
Max discharge length Ø80 - Hor duct	m	35
Max discharge length Ø50 - Vert duct	m	2
Max discharge length Ø60 - Vert duct	m	12
Max discharge length Ø80 - Vert duct	m	35
Electrical specifications		
Voltage-frequency	V/Hz	240/50
Max Absorbed Power	W	138
Insulation rate	IP	X5D
Gas supply		
Nominal supply pressure - Natural Gas	kPa	1.13
Heating Max. fan speed - Natural Gas	Hz	186
D.H.W Max fan speed - Natural Gas	Hz	186
Heating Min. fan speed - Natural Gas	Hz	45
D.H.W Min. fan speed - Natural Gas	Hz	45
Fuel consumption - Natural Gas	MJ/h	135
Nominal Supply pressure - Universal LPG	kPa	2.75
Heating Max. fan speed - Universal LPG	Hz	184
D.H.W Max fan speed - Universal LPG	Hz	184
Heating Min. fan speed - Universal LPG	Hz	45
D.H.W Min. fan speed - Universal LPG	Hz	45
Fuel consumption - Universal LPG	MJ/h	135

2.2.9. TECHNICAL ASSEMBLY

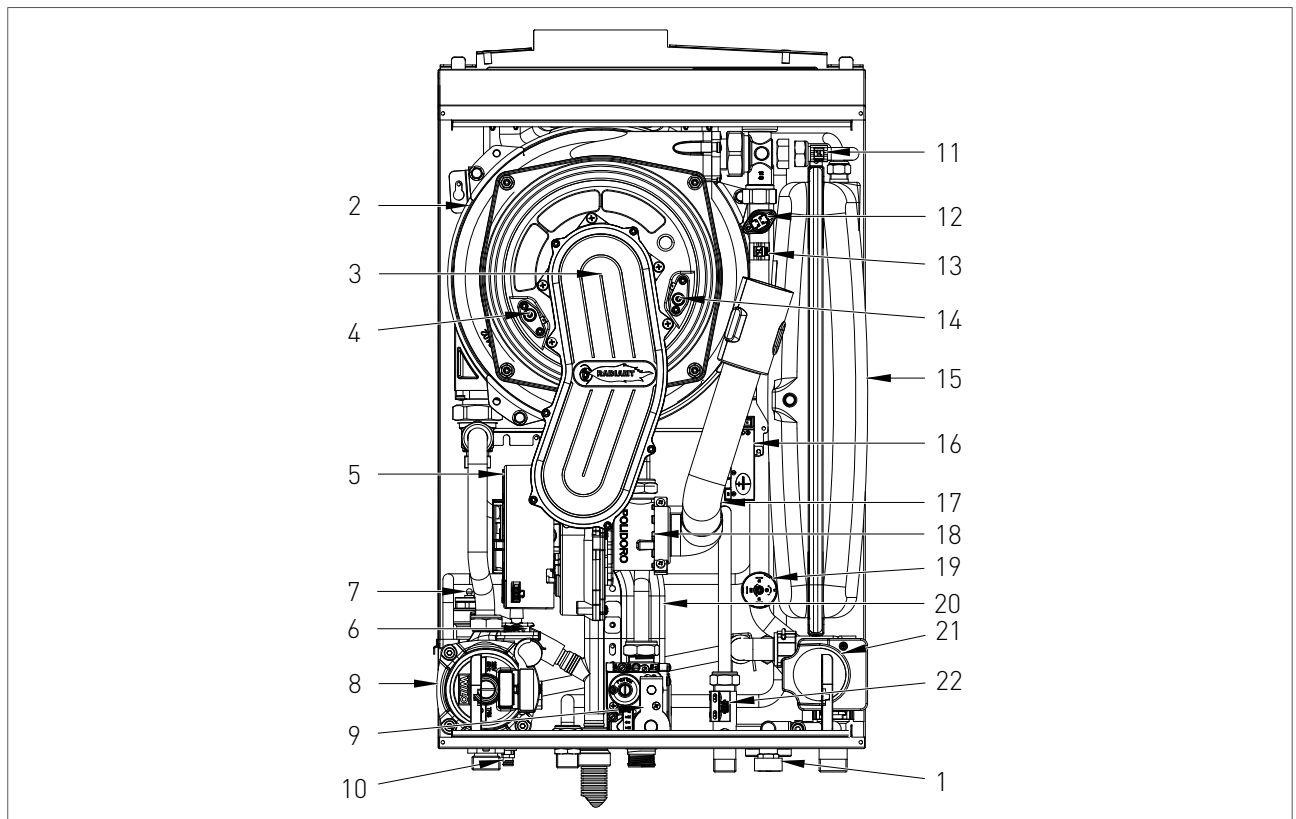

KEY

1. SYSTEM FILLING TAP
2. INTEGRATED HEAT EXCHANGER
3. BURNER UNIT
4. DETECTION ELECTRODE
5. ELECTRIC FAN
6. AIR RELIEF VALVE
7. SAFETY VALVE 3 bar
8. CIRCULATOR
9. GAS VALVE
10. SYSTEM DRAINING TAP
11. DOMESTIC CIRCUIT PROBE
12. SAFETY THERMOSTAT
13. HEATING PROBE
14. LIGHT UP ELECTRODE
15. EXPANSION TANK
16. START-UP TRANSFORMER
17. AIR SUCTION TUBE
18. PROPORTIONAL VENTURI
19. WATER PRESSURE SWITCH
20. CONDENSATE COLLECTION SIPHON
21. DIVERTER VALVE
22. FLOW SWITCH

2.2.10. HYDRAULIC BOARD

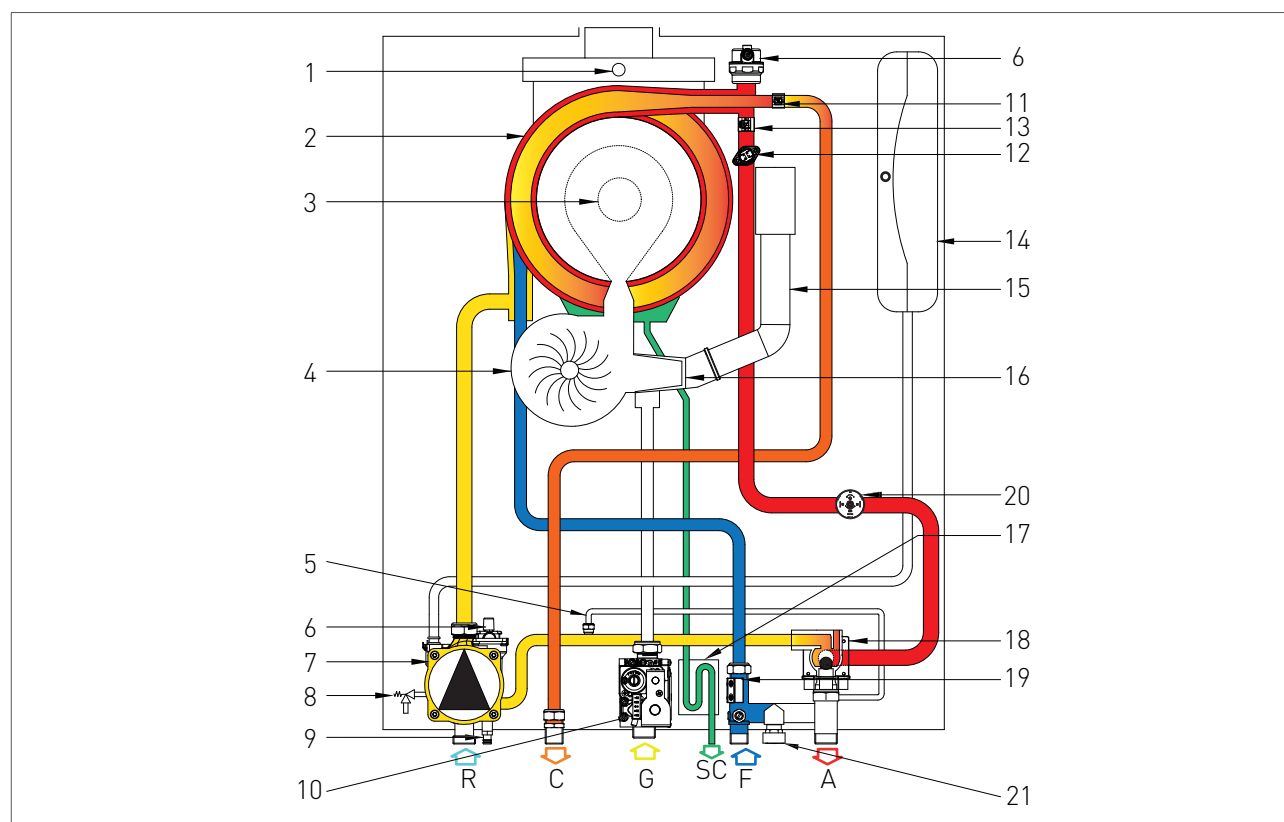
**KEY**

- | | |
|------------------------------|----------------------------------|
| R. HEATING RETURN | 16. PROPORTIONAL VENTURI |
| C. DOMESTIC HOT WATER OUTLET | 17. CONDENSATE COLLECTION SIPHON |
| G. GAS INLET | 18. DIVERTER VALVE |
| SC. CONDENSATE DRAIN | 19. FLOW SWITCH |
| F. COLD WATER INLET | 20. WATER PRESSURE SWITCH |
| A. HEATING FORWARD | 21. SYSTEM FILLING TAP |
| 1. FUMES SAFETY THERMOFUSE | |
| 2. INTEGRATED HEAT EXCHANGER | |
| 3. BURNER UNIT | |
| 4. ELECTRIC FAN | |
| 5. BY-PASS | |
| 6. AIR RELIEF VALVE | |
| 7. CIRCULATOR | |
| 8. SAFETY VALVE 3 bar | |
| 9. SYSTEM DRAINING TAP | |
| 10. GAS VALVE | |
| 11. DOMESTIC CIRCUIT PROBE | |
| 12. SAFETY THERMOSTAT | |
| 13. HEATING PROBE | |
| 14. EXPANSION TANK | |
| 15. AIR SUCTION TUBE | |

2.2.11. 3-WAY VALVE OPERATION

Important: The working position of the 3-way valve is indicated by the color (Red or Blue) visible in the inside of the valve. (see 'C' - fig. 1).

- > The RED color (with C-A) indicates the operation in the Domestic Hot water mode.
- > The BLUE color (with C-B) indicates the operation in Heating mode.

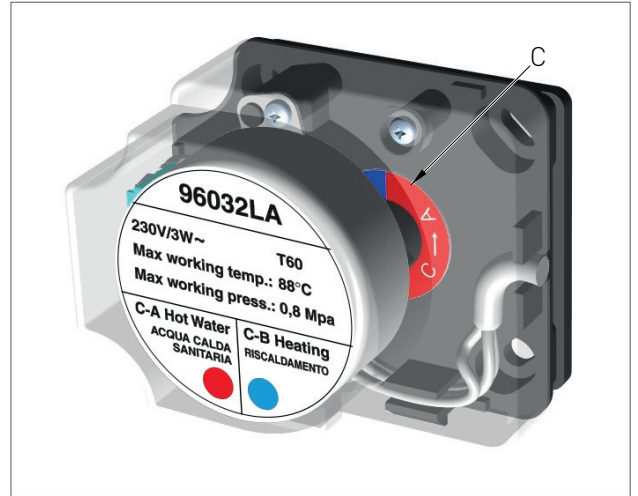



2.2.12. WIRING DIAGRAM

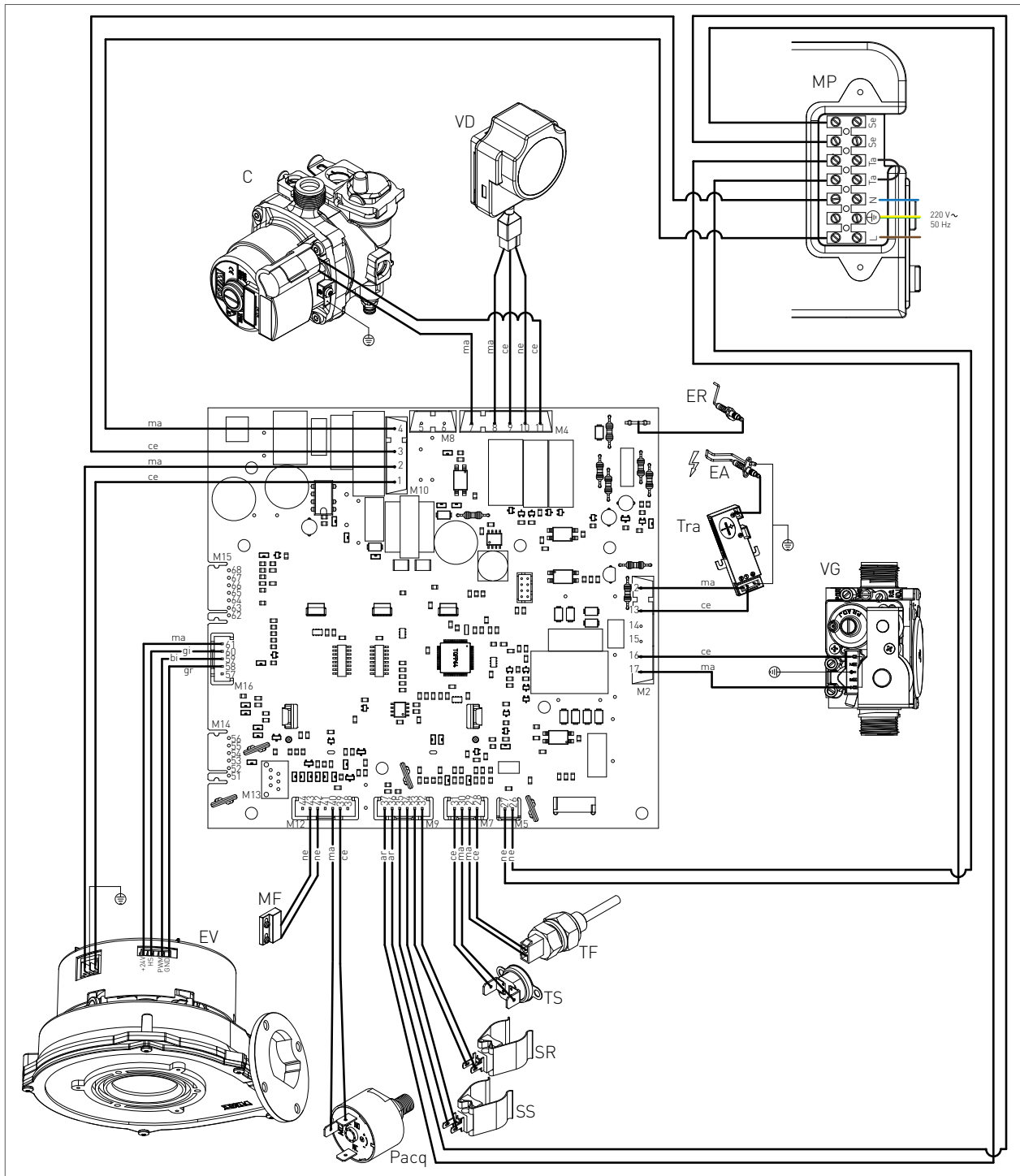

SUPPORT CENTRE

- | | | | |
|------------------------------|-----------------------------|----------------------------|------------|
| ER: DETECTION ELECTRODE | TS: SAFETY THERMOSTAT | MP: PANEL TERMINAL | CE: BLUE |
| EA: START-UP ELECTRODE | PACQ: WATER PRESSURE SWITCH | SE: EXTERNAL PROBE | MA: BROWN |
| C: CIRCULATOR | MF: MICRO-FLOW SWITCH | TA: ENVIRONMENT THERMOSTAT | AR: ORANGE |
| VG: GAS VALVE | SR: HEATING PROBE | L: LINE | GI: YELLOW |
| TRA: START-UP TRANSFORMER | SS: DOMESTIC CIRCUIT PROBE | N: NEUTRAL | BI: WHITE |
| TF: FUMES THERMOFUSE (102°C) | EV: ELECTRIC FAN | NE: BLACK | GR: GREY |
| VD: DIVERTER VALVE | | | |

2.2.13. ACCESSING THE BOILER

For most control and maintenance operations, the panels of the casing have to be removed.

To remove the panel of the boiler, please follow the instructions below (see fig.1):

- › remove the fastening screws (1) placed on the side of the panel flange and remove it;
- › remove the fastening screws (2) placed on the upper and lower side of the panel, and remove it by pulling it towards yourself;
- › remove the fastening screws (3) placed on the lower side of the boiler and remove the connection cover.

To intervene on the front of the boiler, please proceed as follows:

- › remove the fastening screws (4) placed on the front panel;
- › grab the front panel and remove it by pulling it towards yourself;

To intervene on the side panels of the boiler, please proceed as follows:

- › remove the fastening screws (5) placed on the front edge of the side panel;
- › grab the bottom of the panel, and remove it by moving it sideways and pulling it upwards.

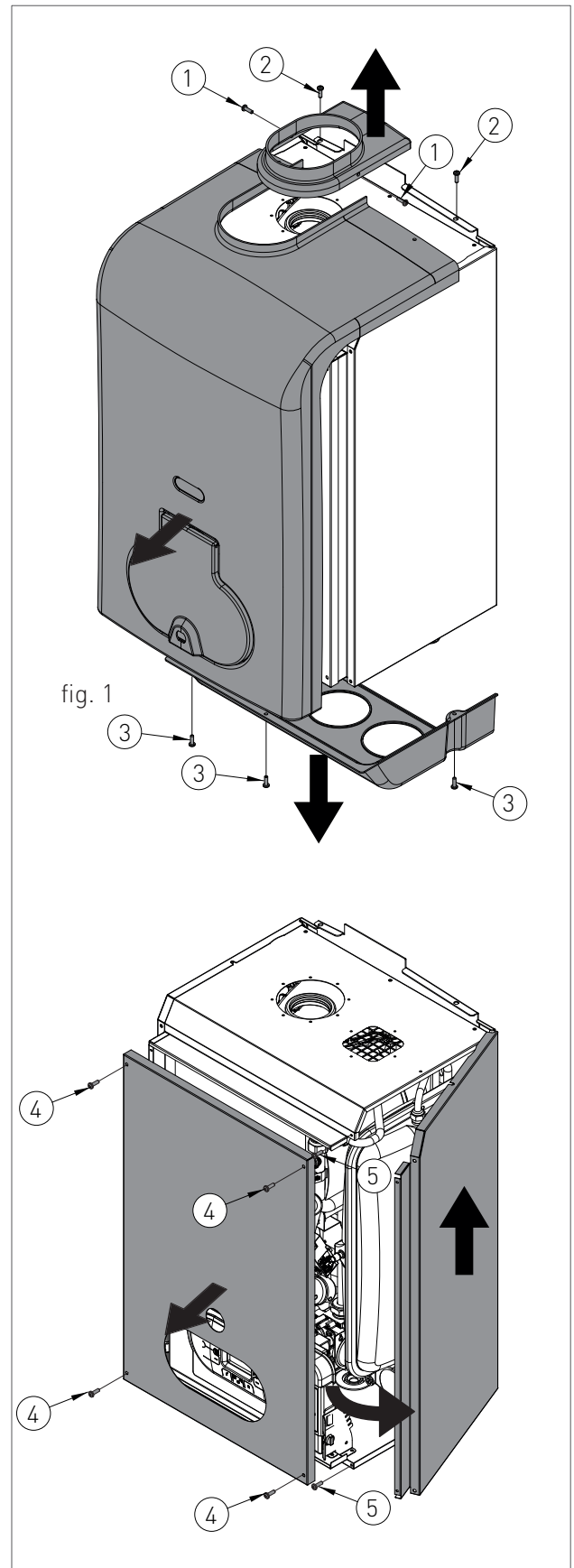

2.2.14. ACCESSING THE ELECTRONIC BOARD

In order to intervene on the wirings of the control panel, please proceed as follows:



DANGER

Cut off the voltage from the main switch.

- > Grab at the same time the support brackets of the control panel (fig. 1) loosening them and turn the panel downwards;
- > unscrew the four fastening screws 1 - fig. 1;
- > remove the crankcase pulling it upwards.

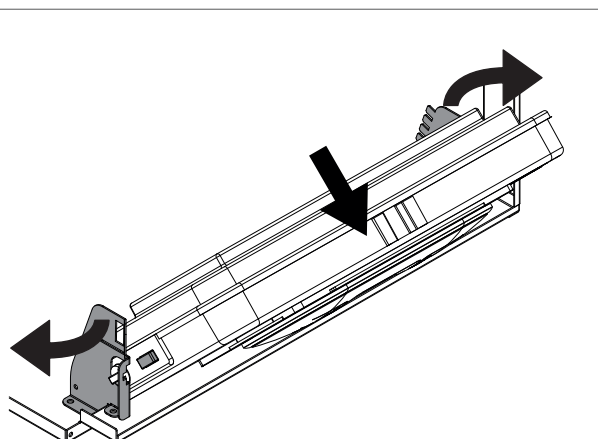
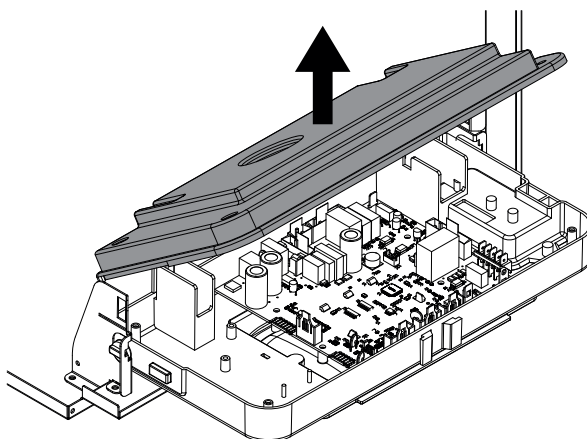
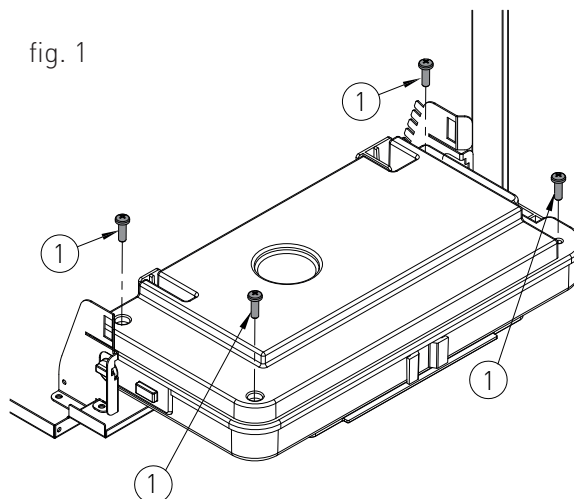

fig. 1



2.2.15. SYSTEM EMPTYING

HEATING SYSTEM EMPTYING

Whenever you need to empty the system, proceed as follows:

- > switch the boiler to "WINTER" mode and activate it;
- > turn off the main power supply switch;
- > wait for the boiler to cool down;
- > connect a flexible tube to the system emptying outlet and connect the other end of the tube to a suitable discharge;
- > turn the discharge tap of the system 'RS' (fig. 1);
- > open the relief valves of the radiators starting from the one at the top and continuing downwards;
- > after draining out all water, close the relief valves of the radiators and the emptying tap.

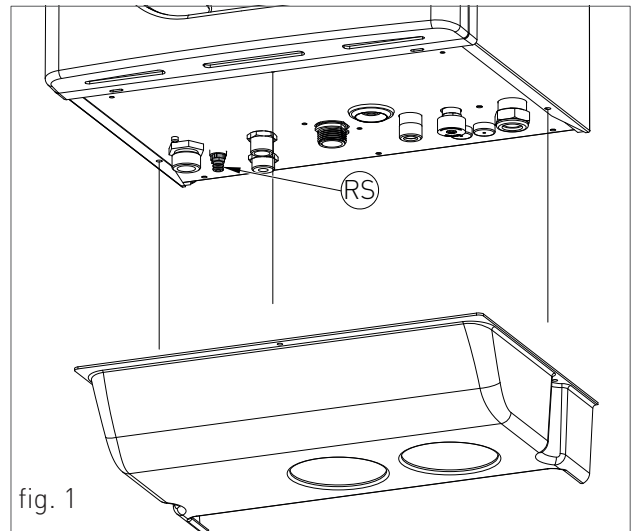

EMPTYING THE DOMESTIC SYSTEM

If there is freezing risk, you have to empty the domestic system as follows:

- > close the main supply tap of the water supply network;
- > open all cold and hot water taps;
- > after completing all operations, close the discharge tap and all previously opened water taps.



2.2.16. FAULT SIGNALLING CODES

To view the last 5 fault signalling codes chronologically, starting with the most recent one, activate the 'OFF' mode by pressing the FUNCTION key and hold the key INFO for 5 seconds. Use keys and of the heating circuit to scroll through the list of saved faults. To reset the fault history press the RESET key. To exit display mode press the INFO key.

CODE	FAULT	POSSIBLE CAUSE	SOLUTION	RESET
E01	FLAME BLOCK	NO FLAME LIGHT UP		MANUAL RESET (PRESS THE RESET KEY).
		GAS MISSING;	CHECK THE ADDUCTION NETWORK;	
		MASS OR BROKEN START-UP ELECTRODE;	REPLACE IT;	
		GAS VALVE BROKEN;	REPLACE IT;	
		SLOW LIGHT UP TOO LOW ADJUSTMENT;	ADJUST MINIMUM OR SLOW LIGHT UP;	
		VALVE INFEED PRESSURE TOO HIGH (ONLY FOR GPL BOILERS).	CHECK THE MAXIMUM ADJUSTMENT PRESSURE	
		WITH FLAME LIGHT UP		
		NEUTRAL AND PHASE INVERTED POWER SUPPLY;	PROPERLY CONNECT THE POWER SUPPLY;	
		DETECTION ELECTRODE BROKEN;	REPLACE IT;	
		DETECTION ELECTRODE CABLE DISCONNECTED.	CHECK THE WIRING.	
ELECTRICAL CURRENT PHASE-PHASE	IF THE TENSION MEASURES BETWEEN NEUTRAL AND GROUND IS ALMOST EQUAL TO THE ONE MEASURED BETWEEN PHASE AND GROUND, YOU HAVE TO INSTALL A PHASE-PHASE TRANSFORMER KIT (COD. 88021LA)			



2. MAINTENANCE

CODE	FAULT	POSSIBLE CAUSE	SOLUTION	RESET
E02	SAFETY THERMOSTAT <i>(95°C)</i>	THERMOSTAT CABLE DISCONNECTED;	CHECK THE WIRING;	AUTOMATIC.
		BROKEN THERMOSTAT.	REPLACE IT.	
E03	FUMES SAFETY <i>THERMOFUSE (102°C)</i>	THERMOFUSE BROKEN;	REPLACE IT;	MANUAL RESET (PRESS THE RESET Ⓡ KEY).
		THERMOFUSE CABLE DISCONNECTED.	CHECK THE WIRING.	
E04	WATER MISSING IN THE SYSTEM	INSUFFICIENT WATER PRESSURE INSIDE THE SYSTEM (LOWER THAN 0.3 BAR);	LOAD THE SYSTEM;	AUTOMATIC.
		WATER PRESSURE SWITCH CABLE DISCONNECTED;	CHECK THE WIRING;	
		WATER PRESSURE SWITCH BROKEN.	REPLACE IT.	
E05	HEATING PROBE	BROKEN OR INCORRECTLY CALIBRATED PROBE (RESISTANCE VALUE 10 KOHM AT 25 °C NTC);	REPLACE IT;	AUTOMATIC.
		DISCONNECTED OR WET PROBE CONNECTOR.	CHECK THE WIRING.	
E06	DOMESTIC CIRCUIT PROBE	BROKEN OR INCORRECTLY CALIBRATED PROBE (RESISTANCE VALUE 10 KOHM AT 25 °C NTC);	REPLACE IT;	AUTOMATIC.
		DISCONNECTED OR WET PROBE CONNECTOR.	CHECK THE WIRING.	
E10	LOW FLOW RATE	THE FLOW RATE VALUE DETECTED BY THE FLOWMETER IS LOWER THAN THE VALUE SET AT PARAMETER P33.	INCREASE THE FLOW RATE OR LOWER THE VALUE AT PARAMETER P33.	AUTOMATIC.



CODE	FAULT	POSSIBLE CAUSE	SOLUTION	RESET
E15	RETURN PROBE	BROKEN OR INCORRECTLY CALIBRATED PROBE (RESISTANCE VALUE 10 KOHM AT 25 °C NTC);	REPLACE IT;	AUTOMATIC.
		DISCONNECTED OR WET PROBE CONNECTOR.	CHECK THE WIRING.	
E16	ELECTRIC FAN	ELECTRIC FAN BOARD BROKEN;	REPLACE IT;	AUTOMATIC.
		ELECTRIC FAN BROKEN;	REPLACE IT;	
		FAULTY POWER SUPPLY CABLE.	REPLACE IT.	
E18	INSUFFICIENT CIRCULATION	EXCHANGER OBSTRUCTED;	CLEAN OR REPLACE THE EXCHANGER;	AUTOMATIC.
		CIRCULATOR BROKEN OR DIRTY IMPELLER.	CLEAN THE IMPELLER OR REPLACE THE CIRCULATOR.	
E21	GENERAL INTERNAL BOARD ERROR	INCORRECT SIGNAL RECOGNITION BY THE MODULATION BOARD MICRO-PROCESSOR.	IF THE MODULATION BOARD DOES NOT RESET THE ERROR AUTOMATICALLY, REPLACE IT.	AUTOMATIC.
E22	PARAMETERS PROGRAMMING REQUEST	MICRO-PROCESSOR MEMORY LOSS.	PARAMETERS REPROGRAMMING.	MANUAL RESET (CUT OFF THE TENSION).
E31	INCOMPATIBLE REMOTE CONTROL	FUNCTION ACTIVE WHEN THE CONNECTED REMOTE CONTROL IS NOT COMPATIBLE WITH THE P.C.B.	REPLACE IT WITH A COMPATIBLE ONE.	AUTOMATIC.
E32	COMMUNICATION ERROR BETWEEN THE BOILER BOARD AND THE MODBUS BOARD	NO ELECTRICAL CONNECTION;	CHECK THE WIRING;	AUTOMATIC.
		MODBUS BOARD BROKEN;	REPLACE IT;	







2. MAINTENANCE

CODE	FAULT	POSSIBLE CAUSE	SOLUTION	RESET
E35	RESIDUAL FLAME	FAULTY DETECTION ELECTRODE;	CLEAN IT OR REPLACE IT;	MANUAL RESET (PRESS THE RESET  KEY).
		FAULTY DETECTION ELECTRODE CABLE;	REPLACE IT;	
		FAULTY MODULATION BOARD.	REPLACE IT.	
E40	SUPPLY VOLTAGE	SUPPLY VOLTAGE OFF THE OPERATION RANGE (≤ 160 VOLTS).	CHECK THE POWER SUPPLY NETWORK (THE ERROR DEACTIVATES AUTOMATICALLY AS SOON AS THE SUPPLY VOLTAGE FALLS BACK WITHIN THE REQUESTED LIMITS).	AUTOMATIC.
E52	COMMUNICATION FAULT BETWEEN MODBUS CONTROLLER AND MODBUS CONTROL UNIT	NO ELECTRICAL CONNECTION;	CHECK THE WIRING;	AUTOMATIC.
		MODBUS CONTROL UNIT BROKEN.	REPLACE IT;	



2.2.17. ACTIVE FUNCTIONS SIGNALLING CODES

CODE	FUNCTION	DESCRIPTION
F07	CHIMNEY SWEEP ACTIVE	YOU CAN ACTIVATE IT BY HOLDING FOR 7 SECONDS THE RESET  KEY AND YOU CAN DEACTIVATE IT BY TURNING OFF THE BOILER. THIS FUNCTION BRINGS THE BOILER TO ITS MINIMUM AND MAXIMUM HEATING POWER FOR 15 MINUTES DEACTIVATING THE MODULATION FUNCTION. GENERALLY USED FOR PERFORMING THE COMBUSTION AND CALIBRATION TESTS.
F08	HEATING CIRCUIT ANTI-FREEZE	IT ACTIVATES AUTOMATICALLY WHEN THE HEATING PROBE DETECTS A TEMPERATURE OF 12°C. THE BOILER OPERATES AT MINIMUM GAS PRESSURE WITH THE DIVERTER VALVE SET TO 'WINTER' MODE. IT DEACTIVATES WHEN THE HEATING FLOW WATER TEMPERATURE REACHES THE 30°C AND, IN PRESENCE OF A RETURN SENSOR, WHEN THE HEATING RETURN WATER TEMPERATURE REACHES THE 20°C.
F09	D.H.W CIRCUIT ANTI-FREEZE	THE FUNCTION IS AUTOMATICALLY ENABLED WHEN THE D.H.W SENSOR DETECTS A TEMPERATURE OF 4 °C. THE BOILER OPERATES AT MINIMUM GAS PRESSURE WITH THE DIVERTER VALVE IN THE 'SUMMER' POSITION. THE FUNCTION IS DISABLED WHEN THE TEMPERATURE DETECTED BY THE SENSOR IS 8 °C IN THE D.H.W CIRCUIT.
F33	SYSTEM AIR RELEASE CYCLE	IT ACTIVATES AUTOMATICALLY AT FIRST BOILER START-UP, PERFORMING FOR 5 MINUTES A SERIES OF CYCLES DURING WHICH THE PUMP IS ACTIVATED FOR 40 SECONDS AND DEACTIVATED FOR 20 SECONDS. REGULAR OPERATION IS ALLOWED ONLY AFTER THIS FUNCTION IS COMPLETED. IT CAN ALSO ACTIVATE DURING NORMAL BOILER OPERATION, IF THE WATER PRESSURE SWITCH CONFIRMATION IS MISSING, WHEN THE CONTACT IS RE-CLOSED, A 2 MINUTES RELEASE CYCLE WILL BE PERFORMED.
FH	FAST H2O	YOU CAN ACTIVATE/DEACTIVATED IT BY HOLDING SIMULTANEOUSLY AND FOR 7 SECONDS THE RESET  AND  OF THE DOMESTIC CIRCUIT  . THE "FAST H2O" FUNCTION GUARANTEES THE IMMEDIATE D.H.W SUPPLY AT THE REQUESTED TEMPERATURE.

2.2.18. GAS CONVERSION



ATTENTION

Make sure that the gas adduction tube is suitable for the new type of fuel with which the boiler is supplied.

- › loosen the two screws '1' (fig.1) from the fastening bush, and remove the air suction tube;
- › unscrew the tube coupling that connects the gas valve to venturi;
- › unscrew the three fastening screws '2' (fig.1) of the venturi 'V' (fig.1) using a 10 key, as shown in figure 2;
- › remove the two screws '3' (fig.3) and apply pressure on the rear side of venturi 'C' (fig.3);
- › replace the body venturi with the one suitable for the type of supply gas (cod. 30-00207 for Natural gas / cod. 30-00201 for Universal LPG) and make sure the tooth 'D' (fig.3) is adjusted downwards on the aluminium ring nut (see fig.3);
- › remount the components following the demounting operations in reverse making sure that gasket 'G' is re-assembled as shown in fig.1;
- › set the boiler to operate with the new type of gas, changing the value of the parameter P02 'GAS TYPE SELECTION' from the control panel (see chapters 'DIGITECH CS PARAMETERS TABLE' and 'ACCESSING AND PROGRAMMING THE PARAMETERS');
- › adjust the CO₂ combustion value as indicated in chapter 'CO₂ VALUE CHECK AND CALIBRATION'.

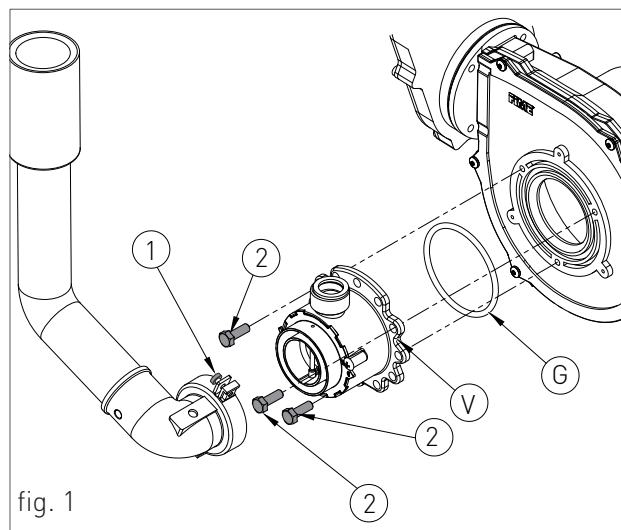

fig. 1

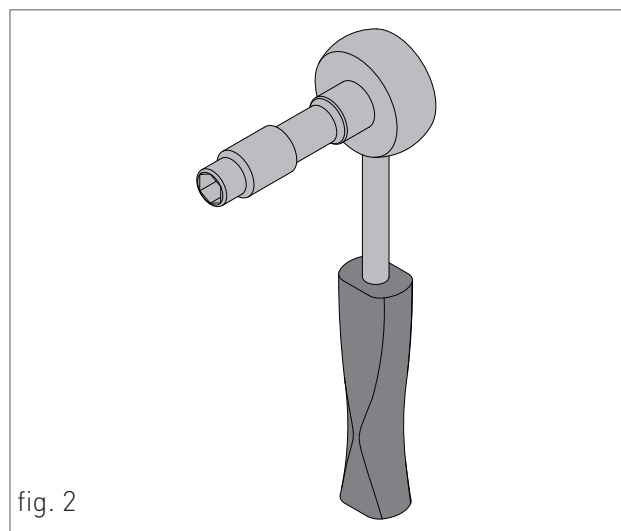

fig. 2

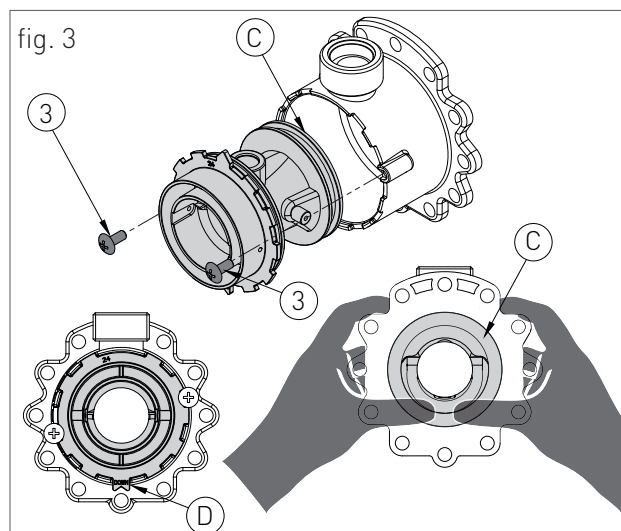

fig. 3



RADIANT BRUCIATORI s.p.a.

Via Pantanelli, 164/166 - 61025 Loc. Montelabbate (PU)

Tel. +39 0721 9079.1 • fax. +39 0721 9079279

e-mail: info@radiant • Internet: <http://www.radiant.it>