



PRODUCTS RANGE

COMBI-TECH®

IHY-SYSTEM®

DUAL-TECH®

ALL INCLUSIVE®
SYSTEM





COMBI-TECH®

THE QUALITY WITHOUT COMPROMISES IN THE MARKETPLACE



YESTERDAY

Since 1959, Radiant develops and produces the key components within its facilities. Today, like yesterday, the endless high-tech evolutions are aimed to guarantee a better efficiency and reliability, all 100% made in Radiant.



TODAY

A great feather in the cap of our production is the newly introduced **COMBI-TECH®** exchanger, made of **stainless steel** spirals **Ø 28 mm**, which guarantees higher efficiency, less head losses and easier cleaning. The highest possible quality in the marketplace.

55 years of an unparalleled experience and know-how allowed Radiant to produce internally the stainless steel exchanger, that now features all the Radiant, condensing units.



COMBI-TECH®



Ø 28 mm

YESTERDAY LIKE TODAY FOR OUR TOMORROW
THE 100% MADE IN RADIANT
FOR A TRUE MADE IN ITALY



★★★★ 92/42/CEE / IP X5D

INSTANTANEOUS CONDENSING BOILER FOR HIGH TEMPERATURE SYSTEMS B-CONDENSE R1HR 24 KW



**NEW
PRODUCT**

B-CONDENSE R1HR: THE CONDENSING BOILER IDEAL FOR THE REPLACEMENTS

- Instantaneous condensing boiler for high temperature systems, available as 24 Kw
- Ideal for replacements
- ★★★★★ Efficiency
- Compact size and easy access for an easier maintenance
- **Cold flame burner**
- **In conformity with the 2018 Eco-Design regulation**



small size



easy of access

Available in the R1HR 24 BOX version,
for inbox installations



FLOW SCHEME

- 1 - RECUPERATOR
- 2 - AIR PRESSURE SWITCH
- 3 - HEAT EXCHANGER
- 4 - IGNITION ELECTRODE
- 5 - CONDENSATE TRAP
- 6 - GAS VALVE
- 7 - 3 bar PRESSURE RELIEF VALVE
- 8 - AIR VENT VALVE
- 9 - CIRCULATING PUMP
- 10 - D.H.W SENSOR
- 11 - SYSTEM DISCHARGE TAP
- 12 - ADJUSTABLE FLOW LIMITER
- 13 - FLUE THERMOSTAT
- 14 - FLUE HOOD
- 15 - FAN
- 16 - EXPANSION VESSEL
- 17 - SAFETY THERMOSTAT
- 18 - HEATING SENSOR
- 19 - IONISATION ELECTRODE
- 20 - BURNER
- 21 - PLATE EXCHANGER
- 22 - BY-PASS
- 23 - WATER PRESSURE SWITCH
- 24 - DIVERTER VALVE
- 25 - FLOWSWITCH
- 26 - SYSTEM FILLING TAP

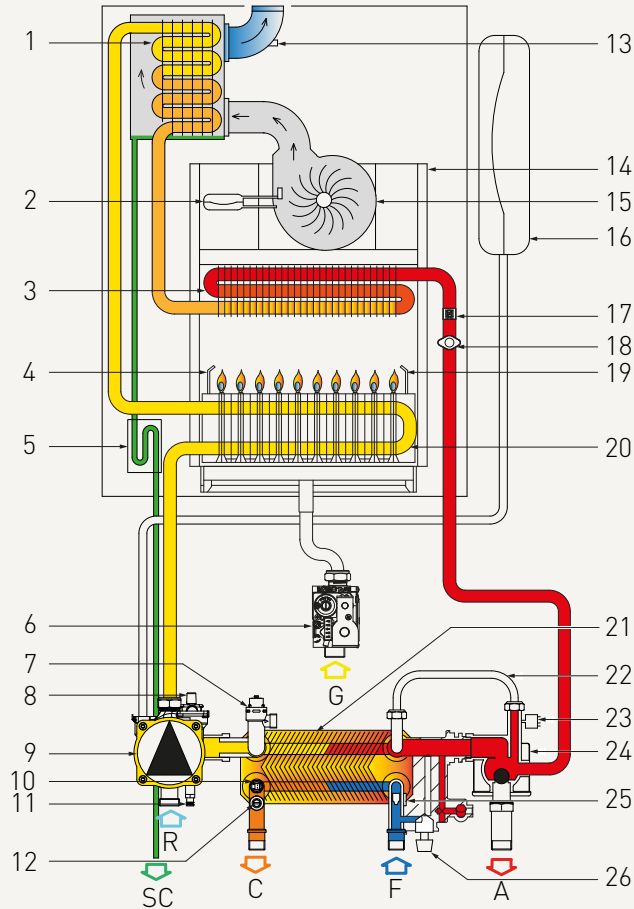

MODEL	HEATING OUTPUT	CLASS NOx	ENERGY EFFICIENCY	SPECIFIC FLOW RATE ACS Δt 30°C (l./min.)
R1HR 24	23,5 kW	VI	★★★★	11,3

DIMENSIONS

B-CONDENSE R1HR 24

W X D X H 410 X 320 X 730

- R: HEATING CIRCUIT RETURN TEMPERATURE Ø 3/4"
- G: GAS Ø 3/4"
- F: COLD WATER Ø 1/2"
- A: HEATING CIRCUIT FLOW TEMPERATURE Ø 3/4"
- C: HOT WATER Ø 1/2"

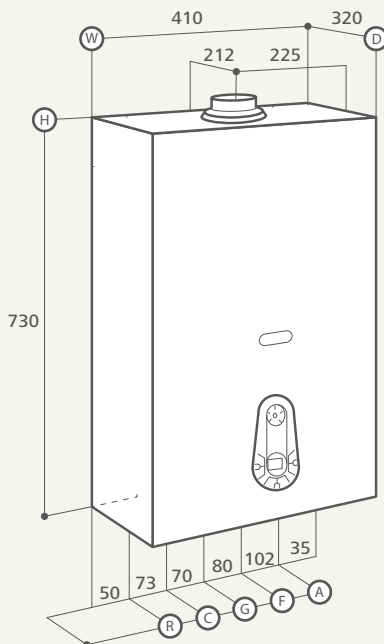



★★★★ 92/42/CEE / IP X5D

CONDENSING INSTANTANEOUS COMBI

COMBI-TECH® - 24 / 28 / 34 KW

COMBI-TECH®: WELL BEING AND TECHNOLOGY ALL IN ONE PRODUCT

- Condensing wall hung instantaneous combi boilers, heating only and D.H.W. instantaneous production too, available as 24, 28 and 34 kW's
- Units equipped with an INOX exchanger Ø 28 mm 100% made in Radiant
- Digitech CS main P.C.B.
- Compact size for easier maintenance
- Enhanced noiseless 52 db



enhanced noiseless 52 dB



Ø 28 mm



COMBI-TECH®



Combi-tech® RANGE is available with R1K boilers heating only and R1K /B heating only with external tank.

FLOW SCHEME

- 1 - SMOKES SAFETY THERMOFUSE
- 2 - INTEGRATED HEAT EXCHANGER
- 3 - BURNER ASSEMBLY
- 4 - COMBUSTION BLOWER
- 5 - BY-PASS
- 6 - AIR RELIEF VALVE
- 7 - CIRCULATING PUMP
- 8 - 3 BAR SAFETY VALVE
- 9 - DISCHARGE TAP
- 10 - GAS VALVE
- 11 - SANITARY SENSOR
- 12 - SAFETY THERMOSTAT
- 13 - HEATING SENSOR
- 14 - EXPANSION TANK
- 15 - FRESH AIR INLET
- 16 - PROPORTIONAL VENTURI
- 17 - CONDENSATE TRAP
- 18 - DIVERTOR VALVE
- 19 - WATER FLOW-SWITCH
- 20 - WATER PRESSURE SWITCH
- 21 - FILLING TAP

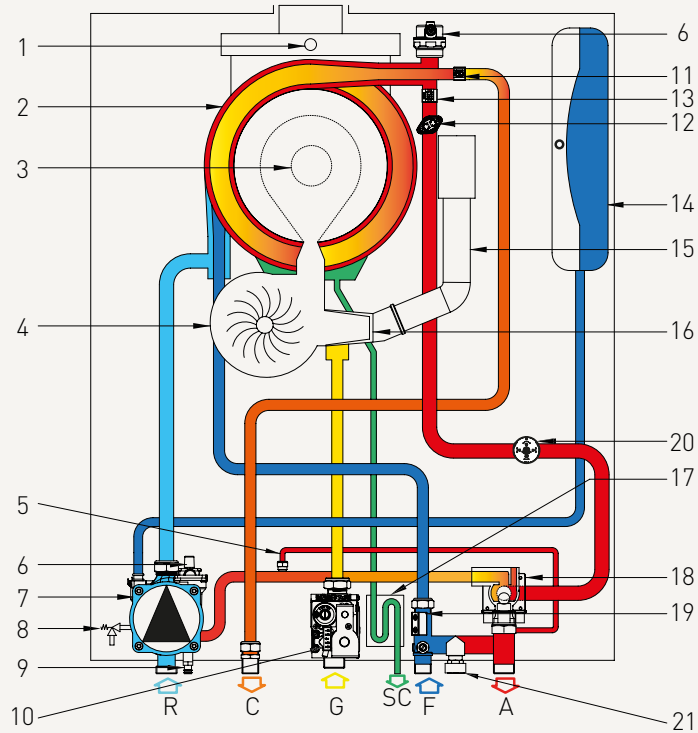

MODEL	HEATING OUTPUT	CLASS NOx	MODULATION	SPECIFIC FLOW RATE ACS Δt 30°C (l./min.)
R1K 24	23,5 kW	VI	1:9	-
R1K 25	25 kW	VI	1:9	-
R1K 34	34 kW	VI	1:9	-
R2K 24	23,5 kW	VI	1:9	11,5
R2K 28	28 kW	VI	1:9	13,2
R2K 34	34 kW	VI	1:9	16



HEATING ONLY



HEATING ONLY /B



INSTANTANEOUS COMBI

R1K 24

R1K 24 /B

R2K 24

R1K 25

R1K 28 /B

R2K 28

R1K 34

R1K 34 /B

R2K 34



★★★★ 92/42/CEE / IP X4D

CONDENSING STORAGE DUAL-TECH® - 24 / 28 / 34 kW



DUAL-TECH®: ALL THE WELL BEING YOU NEED

- Condensing wall hung storage boiler with new dual-tech system equipped with storage tanks 8 and 20 l. capacity available as 24, 28 and 34 kW
- Units equipped with an INOX exchanger Ø 28 mm 100% made in Radiant
- Digitech CS main P.C.B.
- Compact size for easier maintenance
- Enhanced noiseless 52 db

DUAL-TECH®



enhanced noiseless 52 dB



Ø 28 mm



Available with 2 circuits system for high/low temperature, with two pumps and mixing valve.

ALL INCLUSIVE
SYSTEM

DUAL-TECH[®] is the step forward, as for the technology, of the previously patented Radiant DUOPASS[®]. DUAL-TECH[®] is the ideal combination between the exchanger “made in Radiant” COMBI-TECH[®] and the patented assembly Radiant DUOPASS[®]. The DUAL-TECH[®] assembly is made of an integrated double-coil exchanger, fully made in Radiant, that enables an instantaneous highly efficient heat transfer without losses, that replaces the previous system that featured a secondary exchanger.

HEATING MODE

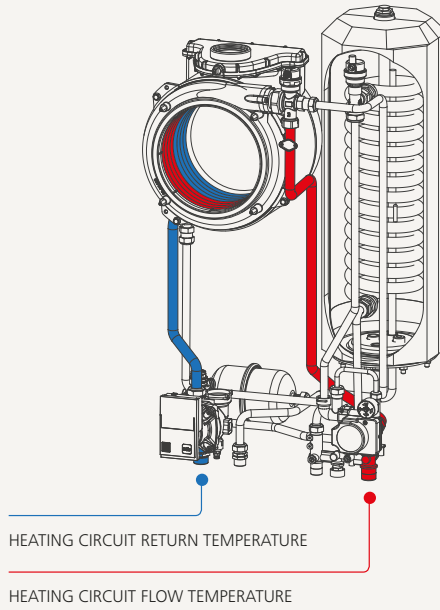

D.H.W. MODE

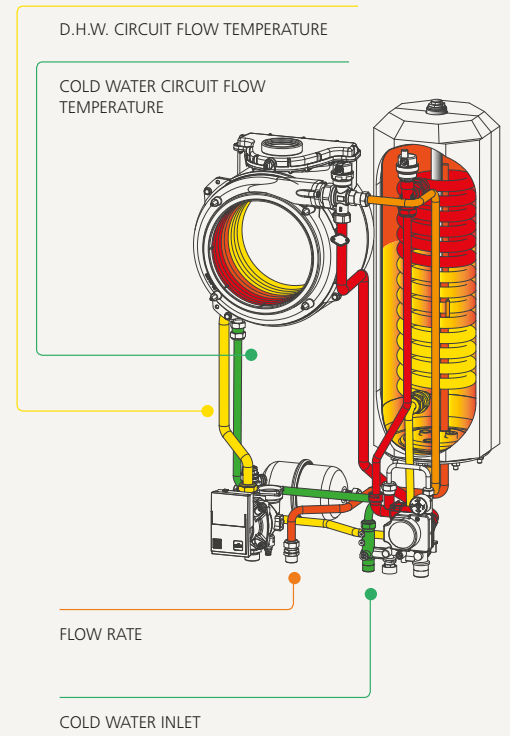

MODEL	HEATING OUTPUT	CLASS NOx	MODULATION	SPECIFIC FLOW RATE ACS Δt 30°C (l./min.)
R2KA 24 /8	23,5 kW	VI	1:9	122,5
R2KA 24 /20	23,5 kW	VI	1:9	135
R2KA 28 /20	28 kW	VI	1:9	152
R2KA 34 /20	34 kW	VI	1:9	185

DUAL-TECH[®]

8 L. STORAGE TANK

R2KA 24 /8

DUAL-TECH[®]

20 L. STORAGE TANK

R2KA 24 /20

R2KA 28 /20

R2KA 34 /20

DUAL-TECH[®]

20 L. STORAGE TANK WITH 2 CIRCUITS SYSTEM

R2KA 24 /20 2V

R2KA 28 /20 2V

R2KA 34 /20 2V

1 / 2 CIRCUITS SYSTEM - HIGH/LOW TEMP.



★★★★ 92/42/CEE / IP X4D

CONDENSING FLOOR STANDING SUPREMA-TECH - 24 / 28 / 34 KW

SUPREMA-TECH: TECHNOLOGY AND ENDLESS D.H.W.

- Condensing Floor standing gas boilers, featuring the new DUAL-TECH® system equipped with stainless steel storage tank 40 or 100 l. capacity
- Units equipped with an INox exchanger Ø 28 mm 100% made in Radiant
- Digitech CS main P.C.B.
- Compact size for easier maintenance
- Enhanced noiseless 52 db



enhanced noiseless 52 dB



Ø 28 mm



DUAL-TECH®



Available with 3 circuits system for high/low temperature, with two pumps and mixing valve.



ALL INCLUSIVE
SYSTEM

DUAL-TECH® is the step forward, as for the technology, of the previously patented Radiant DUOPASS®. DUAL-TECH® is the ideal combination between the exchanger “made in Radiant” COMBI-TECH® and the patented assembly Radiant DUOPASS®. The DUAL-TECH® assembly is made of an integrated double-coil exchanger, fully made in Radiant, that enables an instantaneous highly efficient heat transfer without losses, that replaces the previous system that featured a secondary exchanger.

HEATING MODE

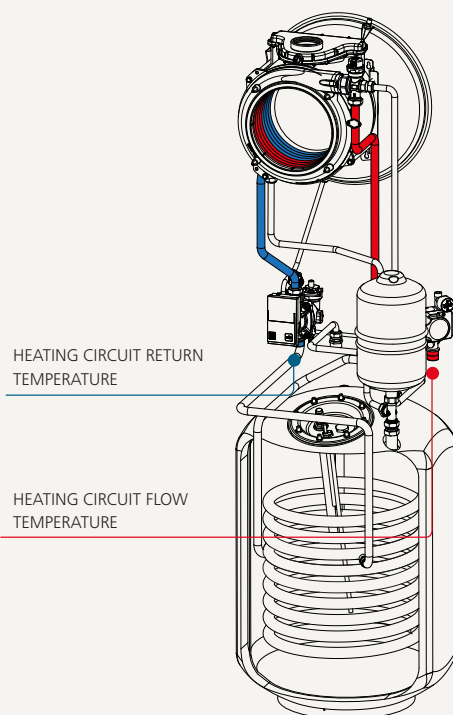

D.H.W. MODE

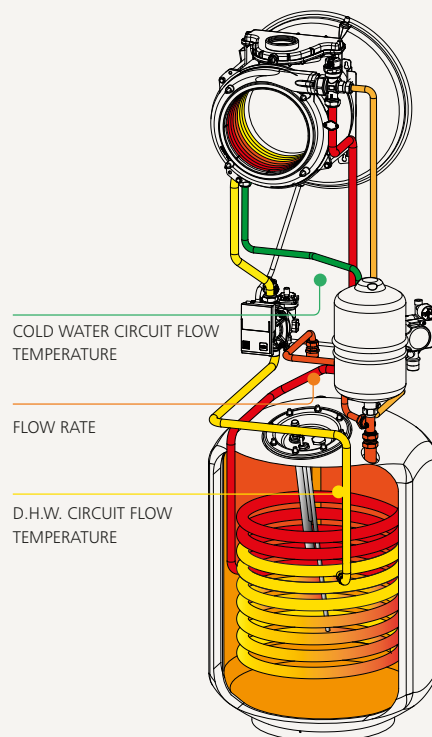

MODEL	HEATING OUTPUT	CLASS NOx	MODULATION	SPECIFIC FLOW RATE ACS Δt 30°C (l./min.)
R1KG 24	23,5 kW	VI	1:9	-
R1KG 25	25 kW	VI	1:9	-
R1KG 34	34 kW	VI	1:9	-
R2KA 24 /40	23,5 kW	VI	1:9	160
R2KA 28 /40	28 kW	VI	1:9	176
R2KA 34 /40	34 kW	VI	1:9	208
R2KA 24 /100	23,5 kW	VI	1:9	228
R2KA 28 /100	28 kW	VI	1:9	235
R2KA 34 /100	34 kW	VI	1:9	275

COMBI-TECH®

HEATING ONLY

DUAL-TECH®

40 L. STORAGE TANK

DUAL-TECH®

100 L. STORAGE TANK

DUAL-TECH®

100 L. STORAGE TANK WITH 3 CIRCUITS SYSTEM

R1KG 24

R2KA 24 /40

R2KA 24 /100

R2KA 24 /100 3VIE

R1KG 25

R2KA 28 /40

R2KA 28 /100

R2KA 28 /100 3VIE

R1KG 34

R2KA 34 /40

R2KA 34 /100

R2KA 34 /100 3VIE

1 / 2 CIRCUITS SYSTEM - HIGH/LOW TEMP.



★★★★ 92/42/CEE / IP X4D

RAIN - BOX CONDENSING COMBI-TECH® / DUAL-TECH® 24 / 28 / 34 KW



RAIN-BOX: FOR A GREEN LIFE ANYWHERE

- Condensing wall hung gas boilers, featuring the new ABS casing panels aimed to suit all outdoor conditions, available as 24, 28 and 34 kW's
- Units equipped with an INOX exchanger Ø 28 mm 100% made in Radiant
- Digitech CS main P.C.B.
- Compact size for easier maintenance
- Enhanced noiseless 52 db



NEW FLUE KIT SYTEM



enhanced noiseless 52 dB



Ø 28 mm



Available in a large number of combinations
Box - Maxibox.

DUAL-TECH® is the step forward, as for the technology, of the previously patented Radiant DUOPASS®. DUAL-TECH® is the ideal combination between the exchanger “made in Radiant” COMBI-TECH® and the patented assembly Radiant DUOPASS®. The DUAL-TECH® assembly is made of an integrated double-coil exchanger, fully made in Radiant, that enables an instantaneous highly efficient heat transfer without losses, that replaces the previous system that featured a secondary exchanger.

HEATING MODE

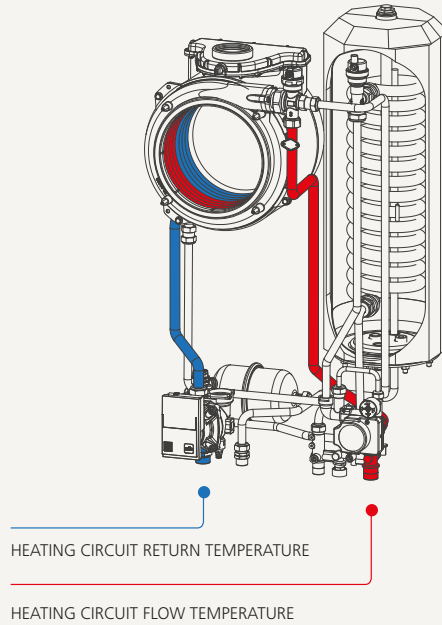

D.H.W. MODE

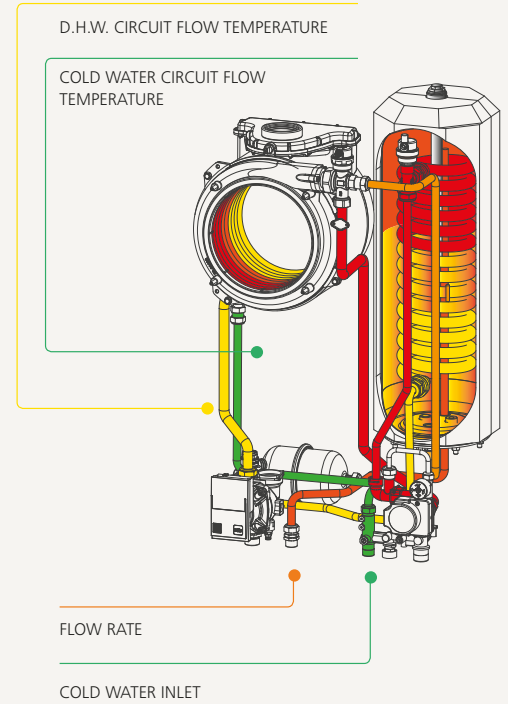

MODEL	HEATING OUTPUT	CLASS NOx	MODULATION	SPECIFIC FLOW RATE ACS Δt 30°C (l./min.)
R1K 24	23,5 kW	VI	1:9	-
R1K 25	28 kW	VI	1:9	-
R1K 34	34 kW	VI	1:9	-
R2K 24	23,5 kW	VI	1:9	11,5
R2K 28	28 kW	VI	1:9	13,2
R2K 34	34 kW	VI	1:9	16
R2KA 24 /8	23,5 kW	VI	1:9	122,5 (l./10min.)
R2KA 24 /20	28 kW	VI	1:9	135 (l./10min.)



HEATING ONLY



INSTANTANEOUS COMBI



8 L. STORAGE TANK



20 L. STORAGE TANK



100 L. STORAGE TANK WITH 3 CIRCUITS SYSTEM

R1K 24/25/34 RAIN

R2K 24/28/34 RAIN

R2KA 24 /8 BOX

R2KA 24 /20 BOX

R2KA 24 /20 2V BOX

R1K 24 BOX

R2K 24 BOX

R1K 24 /B BOX

R1HR 24 BOX



CONDENSING WATER HEATER FLOW-TECH SFK - 16 / 20 / 29 LITRES

FLOW-TECH SFK: THE FIRST TANKLESS WATER HEATER THAT THINKS IT'S A BOILER

- Condensing tankless water heater available as 28, 34 and 50 kW's
- Units equipped with an INox exchanger Ø 28 mm 100% made in Radiant
- Digitech CS main P.C.B.
- Compact size for easier maintenance
- Enhanced noiseless 52 db



enhanced noiseless 52 dB



Ø 28 mm



integrated re-circulation



modulation 1:10



Available as outdoor installation (28 - 34 kw)

DRAW MODE: RECIRCULATION NON ACTIVE

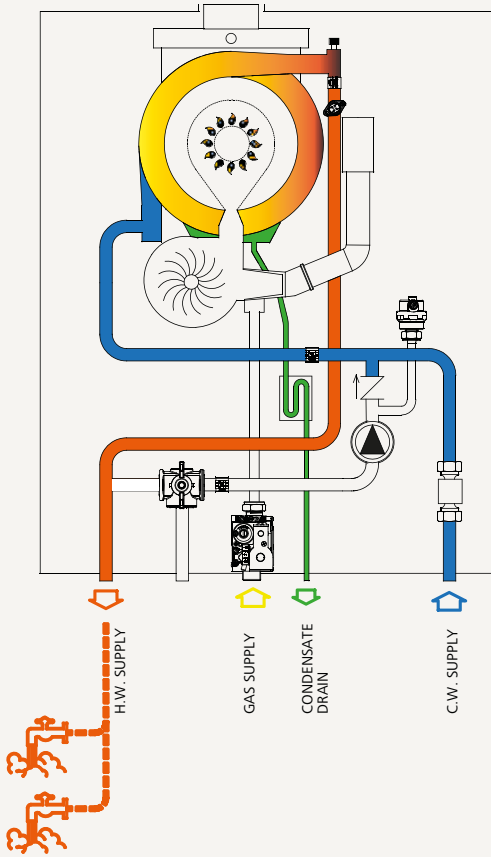

RECIRCULATION MODE (POST CIRCULATION):
RECIRCULATION ACTIVE

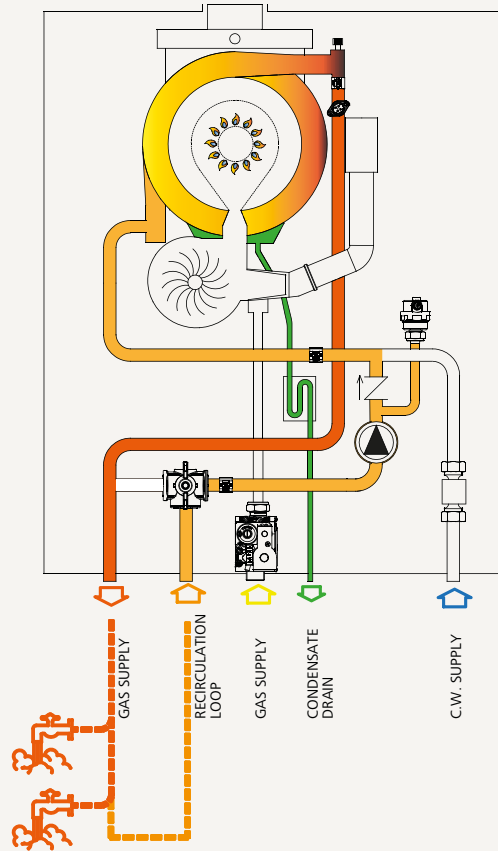

MODEL	HEATING OUTPUT	MODULATION	SPECIFIC FLOW RATE Δt 25°C (l./min.)
SFK 16	28 kW	1:9	16
SFK 20	34 kW	1:9	20
SFK 29	50 kW	1:10	29

DIMENSIONS

FLOW-TECH SFK 16 - 20

W X D X H 410 X 310 X 640

- C: HOT WATER Ø 3/2"
- G: GAS Ø 3/4"
- F: COLD WATER Ø 3/4"
- RC: RECIRCULATION LOOP Ø 3/4"

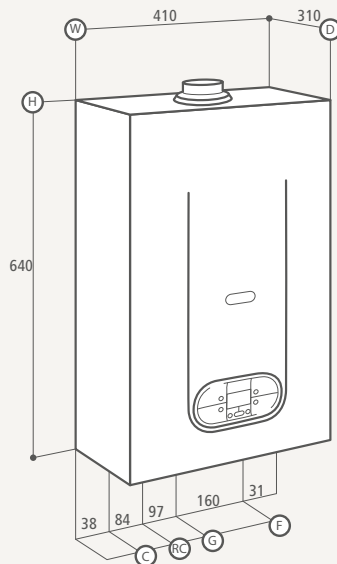

FLOW-TECH 29

W X D X H 410 X 485 X 640

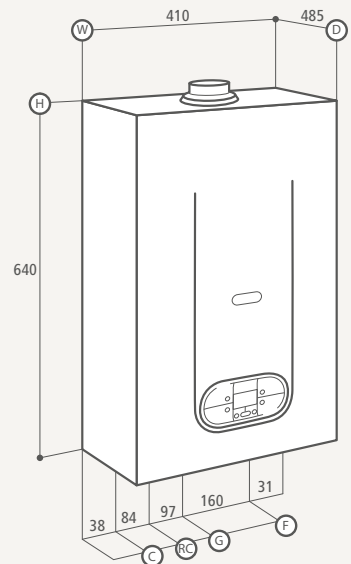



CASCADE CONDENSING WATER HEATER

Solution suitable for commercial installations such as gyms, coiffeurs, beauty centers and sports facilities, where the DHW request fluctuates according to the bands hours, due to the not always homogeneous influx of customers. As well as the recirculation integrated in the water heater, the built-in control unit can manage an external recirculation with the aid of an additional pump (optional) and an external storage tank, to ensure the greatest comfort. Cascade water heaters systems made by a maximum of 6 units managed by one control unit reaching a 1 up to 60 modulation.

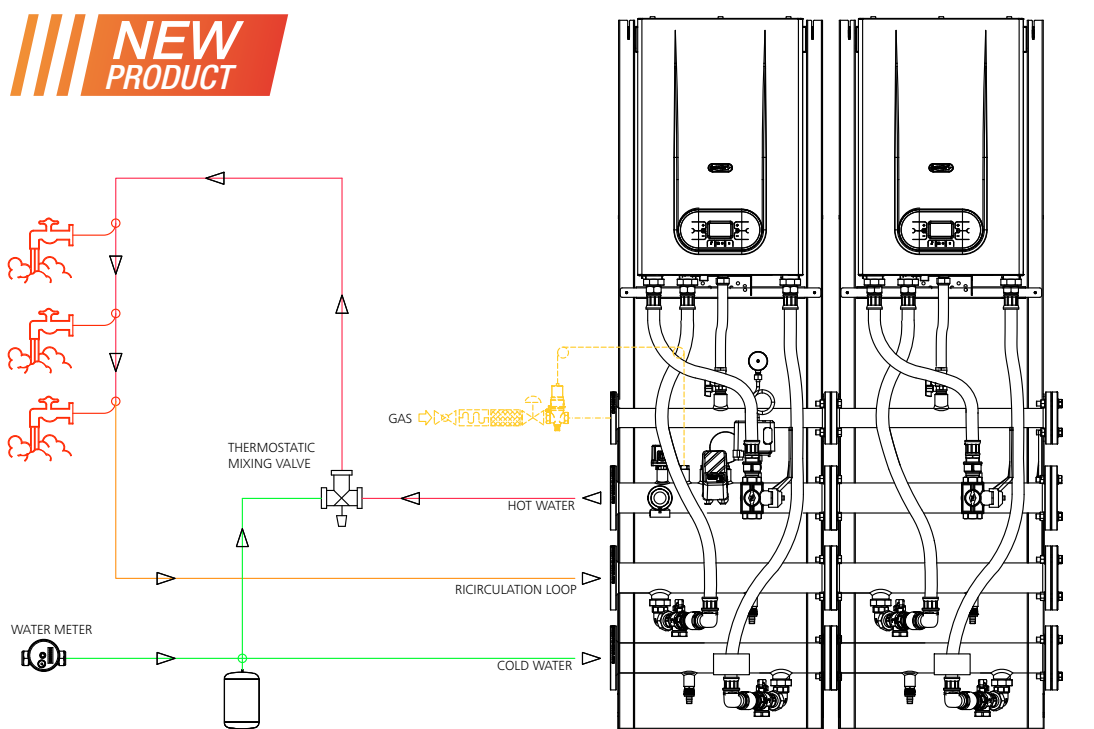





★★★★ 92/42/CEE / IP X4D

HIGH POWER BOILERS FROM 50, 75 AND 100 kW FOR INDIVIDUAL AND CASCADE INSTALLATIONS



The High Power series is made by **R1K 50**, **R1K 75** and **R1K 100** boiler models. All equipped with **COMBI-TECH®** heat exchanger, 100% made in Radiant, with Ø 28 mm **stainless steel spiral single pipe**.

R1K 75 and **R1K 100** models are equipped with 2 boilers within a single boiler body, offering a size advantage, 70 cm wide, as well as a benefit in terms of power, because configurable from 75 Kw (50 + 25 kW) and 100 kW (50 + 50 kW).

This constructive solution has brought many advantages in terms of performances and reliability, such as a 1:20 modulation (75 and 100 kw), the possibility of excluding one boiler, which in case of one boiler failure, allows the technician to never leave the system shut down with the other boiler functioning. The boiler electronic consists into 2 printed circuit boards, the main pcb (master) with the parameters and settings access and the secondary one (slave), for the second boiler functioning.



R1K 75 - R1K 100

HIGH POWER BOILERS FROM 50, 75 AND 100 kW FOR WALL HANG OUTDOOR INSTALLATION

**NEW
PRODUCT**



Thanks to the enormous versatility and the high performances, the **R1K HIGH POWER** series, is now available for outdoor installations. Designed to be adapted to outdoor spaces, coastal areas included, these boilers are equipped with a protective ABS casing, (as for the “moduli” series) they offer a high IPX 5D electrical protection and can be installed under heavy rains.

With the same performances and reliability of the indoor series, the **R1K HIGH POWER RAIN** series will be available in the following 3 outputs: **50, 75** and **100 kW**. Ideal for “SPLIT” combined systems, with an outdoor condensing boiler and indoor fan heaters.



frost
protection



rain protection



R1K 75 RAIN - R1K 100 RAIN



SISTEMA SERIES MODULAR BOILERS FROM 50 TO 800 KW

The modular boilers composing the **SISTEMA series** are pre-mixed condensing units for heating only. **50, 75 and 100 kW boilers with one or two Ø 28 mm stainless steel exchangers, all made in Radiant** to meet the needs of high power in an extremely reduced space. These boilers are designed for individual or cascade installation and are independent of each other.

Radiant has met installation flexibility requested by designers, and ease of installation required by installers, by creating the **SISTEMI series**: it's pre-configured in sets ranging from 50 to 500 kW (over 500 kW, please contact our technical department) complete with boilers, frames, manifolds and control unit. Hydraulic separator, safety valves, fuel interception valve and flue kit are optional to be ordered separately.

The new SISTEMA series is available in 50, 75 and 100 kW outputs for individual installation in SISTEMA VERTICALE R type (heating only) and RS type (with 3-way valve kit for the installation of a remote storage tank), with integrated hydraulic separator.



ADVANTAGES FOR THE FINAL USER

- MODULATION 1:20
- greater energy savings
- low maintenance costs
- lower environmental impact.



50 kW

SISTEMA SERIES

HY DRAULIC COMPENSATOR
KIT DN 150 da 100 a 250 kW

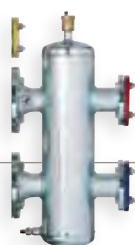

OPTIONAL

HY DRAULIC COMPENSATOR
KIT DN 220 da 300 a 800 KW



PLATE EXCANGER



FUEL INTERCEPTION VALVE



INDIVIDUAL SISTEMA

50 kW
75 kW
100 kW

CASCADE SISTEMA FROM 2,5"

125 kW
150 kW
175 kW
200 kW
250 kW
275 kW
300 kW

CASCADE SISTEMA FROM 4"

350 kW
375 kW
400 kW
450 kW
475 kW
500 kW



250 kW



MODULO SERIES

INDIVIDUAL AND CASCADE INSTALLATION

MODULES FROM 50 TO 800 KW

The modular condensing boilers are pre-mixed condensation units for heating only. In order to meet the needs of high power in an extremely reduced space, Radiant has introduced **the new small-sized 75 and 100 kW modules** in addition to the existing 50 kW one.

The modules, independent of each other, can be modularly coupled and are designed for individual or cascade installation.

Radiant provides a wide range of pre-configured solutions, from 50 to 500 kW to meet all needs. Radiant has met installation flexibility requested by designers and ease of installation required by installers by providing multiple system solutions as well as a wide range of accessories. Last but not least are the advantages for the end user: greater energy savings, respect for the environment and maximum reliability over time.

The NEW MODULES are also available in 50, 75 and 100 kW for individual R1BK VERTICAL installation complete with integrated hydraulic compensator



- cascade installation
- MODULATION 1:20
- outputs from 50, 75 and 100 kW
- max 800 kW
- reduced dimensions
- suitable for outdoor installation
- robust and resistant cabinets
- modular flue systems



MODULO INDIVIDUAL AND CASCADE INSTALLATION MODULES FROM 50 TO 800 KW

HY DRAULIC COMPENSATOR
KIT DN 150 da 100 a 250 kW

HY DRAULIC COMPENSATOR
KIT DN 220 da 300 a 800 kW

PLATE EXCANGER

FUEL INTERCEPTION VALVE

OPTIONAL



INDIVIDUAL MODULO

- 50 kW
- 75 kW
- 100 kW

CASCADE MODULO FROM 2,5"

- 125 kW
- 150 kW
- 175 kW
- 200 kW
- 250 kW
- 275 kW
- 300 kW

CASCADE MODULO FROM 4"

- 350 kW
- 375 kW
- 400 kW
- 450 kW
- 475 kW
- 500 kW



50 kW

100 kW

100 kW



HYBRID SYSTEMS

COMFORT AND SAVING 12 MONTHS A YEAR

RADIANT HEATING AND COOLING SYSTEMS

Radiant, always attentive to the use of renewable sources and to technological innovations, offers 2 types of hybrid systems: a modular box and an integrated boiler.

The heart of the system is the Made in Radiant **COMBI-TECH**[®] boiler running on natural gas or LPG and deriving from 60 years of experience. The range of products already on the market is able to satisfy every single residential need, either individual, multiple or for condominium; either for heating, cooling or dhw.

COMBI-TECH[®] has been matched with other technologies, such as solar and electric, to improve seasonal efficiency, lowering the environmental impact in compliance with existing and future regulations; a domestic air conditioning system capable of managing outdoor temperatures from below zero up to + 46 ° C, even in the presence of very high humidity levels, both in heating and cooling modes. With class A++ products, Radiant satisfies all types of requests in compliance with energy efficiency regulations for new buildings and renovations.

IHY-SYSTEM[®]



solar



electric



gas

Hy Domestic System[®]



1 CIRCUIT
2 CIRCUITS
3 CIRCUITS

Sim System

NEW PRODUCT

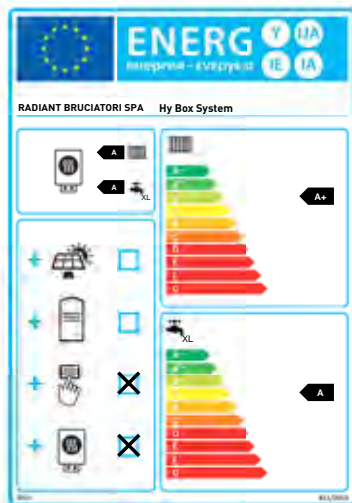
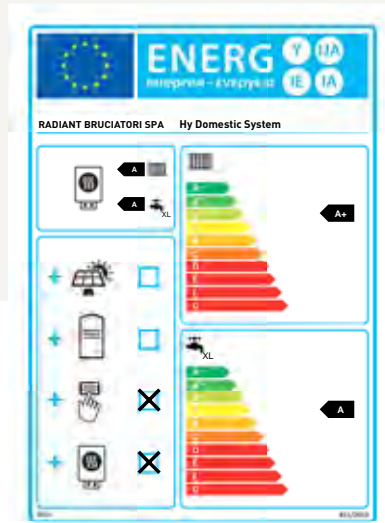

Hy Box System[®]



1A 1B
1A 2B

Hy SolarBox System[®]



1A 1B
1A 2B

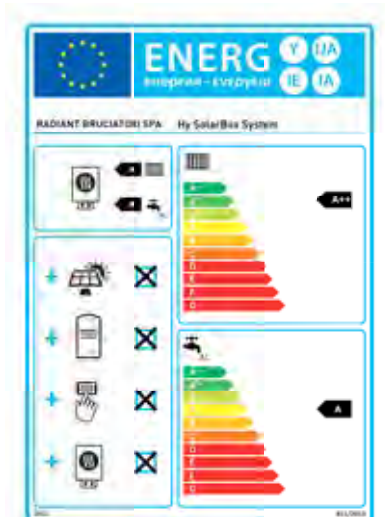



R2K HY DOMESTIC SYSTEM®

CLASS A++ FOR REDUCED SPACES



NEW PRODUCT

EFFICIENCY
AND INNOVATION
PROJECT
2018

Pre-mixed instantaneous condensing boiler with made in Radiant integrated **COMBI-TECH®** stainless steel exchanger.

- 20 litres buffer tank integrated into the boiler.
- Electronics with integrated system managing board that determines the logic of activation of the gas boiler to supplement the renewable source. It includes relevant temperature sensors and it's controlled by a Remote Control that allows the programming of the main functions of the system itself and the temperature control of an area of the system.
- Hydraulic distribution unit with mixed circuit pump.
- Air-Water heat pump.
- Inverter for outdoor installation.



gas



A++ energy class



electric



small size



for condominium apartments installations

DOMESTIC HY SYSTEM® IS IDEAL FOR INSTALLATIONS IN CONDOMINIUM APARTMENTS WITH BALCONY WHERE, DUE TO LACK OF SPACE AND AESTHETICS RESTRICTIONS, CHOICES ARE LIMITED

Example of hybrid system composed of 24 kW Domestic Hy System®, 5 kW heat pump.

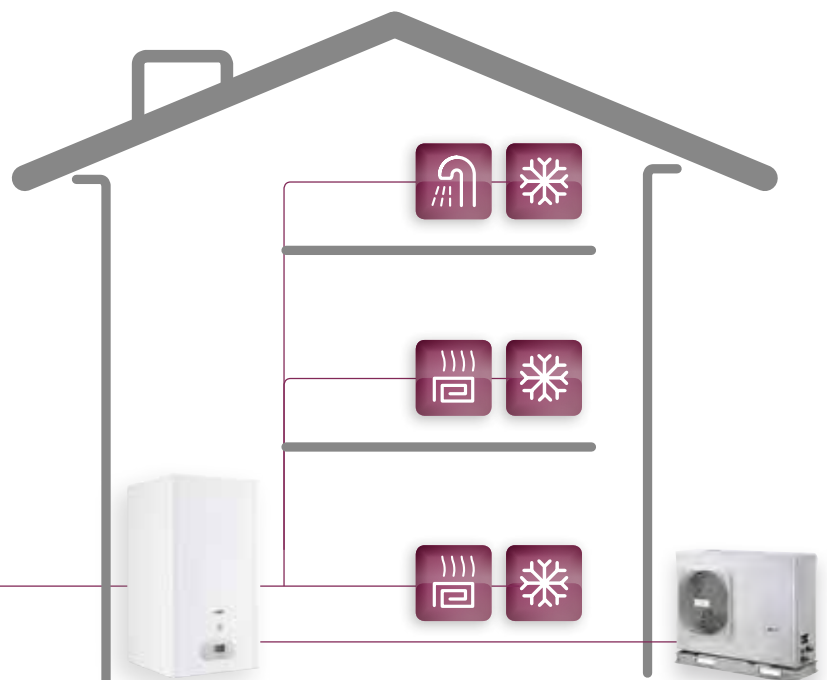

HY SOLAR BOX SYSTEM[®] MODULAR HYBRID SYSTEM

Radiant **HY BOX** and **HY SOLARBOX SYSTEM[®]** offer the user the possibility to better choose the most economical energy sources depending on the season, always guaranteeing the service even if, due to a failure, one of the boilers stops working. In residential applications, in the context of new buildings or major renovations, Radiant **HY BOX** and **HY SOLARBOX SYSTEM[®]** allow to achieve A++ energy class.

HY BOX SYSTEM[®] IS PROPOSED IN TWO VERSIONS, WITH OR WITHOUT THE ADDITION OF RENEWABLE ENERGY SOURCES LIKE SOLAR PANELS. THE WHOLE UNIT IS POSITIONED INSIDE AN IN-WALL METAL BOX



solar



A++ energy class



gas



facilità di accesso



electric

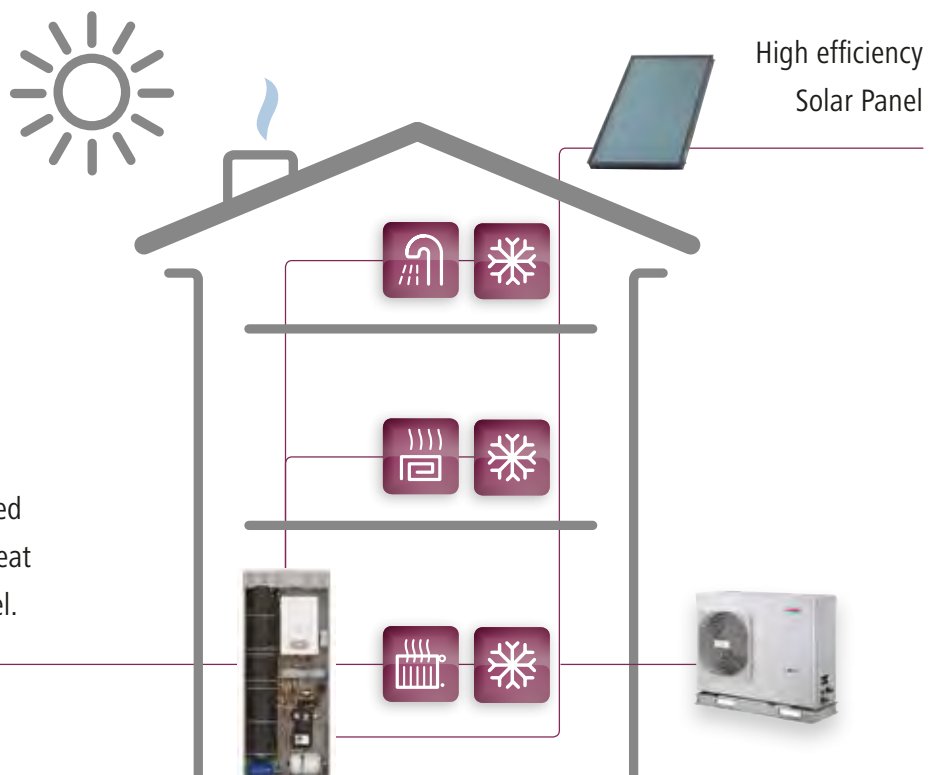

Example of hybrid system composed of Hy Solarbox System[®], + 5 kW heat pump, + high efficiency solar panel.



SOLARBOX SYSTEM®

RADIANT TECHNOLOGY

With **SOLARBOX SYSTEM®**, Radiant presents the market with a wide array of modular boilers to meet every investment customers intend to make. For their energy saving scheme and low impact on the environment, Radiant recommends fitting **R1K /B**, **R2K** and **R2KA /8** condensing boilers.

SOLAR CONTROL KIT

Composed by hydraulic unit, sensors, solar control modules safety devices, 25 l. solar expansion vessel, 8 l. D.H.W. expansion vessel and mixing unit. The solar management kit has its own electronic board interfacing with the one of the boiler in order to provide full economic management of domestic hot water production through the use of a solar panel.

WATER KIT HIGH/LOW TEMPERATURE

The kit comes complete with: hydraulic separator, variable speed pump and electronic board capable of providing full management of high and low temperature.

SINGLE AND DOUBLE COIL TANK

Available in single coil version for the solar integration only, combined with instantaneous boilers. It's also available in double coil version for the solar integration and the domestic hot water production, combined



EASY OF ASSEMBLY AND MULTIPLE ACCESS

A - One-piece metal casing
made from one steel sheet only
for improved structure sturdiness.

B - 2-leaf door
having reduced overall dimensions to facilitate opening
in limited space and improve access.

with heating boilers /B only, with the possibility to install a pump for the re-circulation.

SOLARBOX SYSTEM® is composed by various elements: in-wall casing box, condensing boiler and solar management kit with 1 or more circuits. **SOLARBOX SYSTEM®** consists of an in-wall part and an external part with easy two-door access; it is equipped with a pipework jig complete with standard valves.

This important technical solution by Radiant enables the technician to test the system before installing the boiler and especially, before finishing the walls and floors of the flat and/or building. Solarbox has been designed to house a wide choice of boilers with outputs ranging from 24 to 34 kW and offers the possibility to fit, an additional high and low temperature kit. The pipework jig is centred to allow the water connections to be arranged either from the bottom, right or left hand side.

E - Right Outlet
through
pre-moulded slot

C - Left Outlet
through pre-moulded slot

F - Downward Outlet
through pre-moulded slot

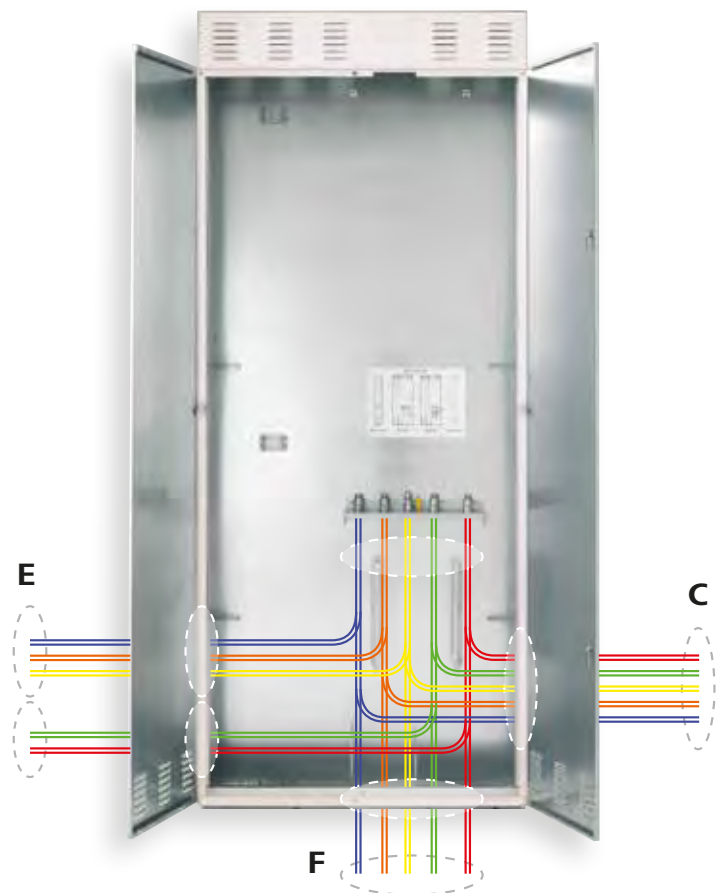



SOLAR-TECH SYSTEM®

24 / 28 / 34 kW

Solar-tech R2ka is the new range condensing storage of boilers with stainless steel 150 or 200 l. solar tank. Solar-tech features a control module with 2 temperature sensors for managing the collector and the solar circuit pump.

Solar-tech is available with integrated components to manage several high and low temperature zones and which include a 3" hydraulic separator, a high temperature circuit pump and two modulating low temperature pumps, controlled by the new fully modulating electronic board.

With Solar-tech R2KA, Radiant offers a multi-function product that is extremely flexible in its composition, for the management of either a solar panel or double or triple circuits. Furthermore, a pump with programmable timer for recirculation utility is also available as optional.

Solar Thermic System®
combined with Solar-tech
200 l. storage tank and
3 ways high/low
temperature solar kit.

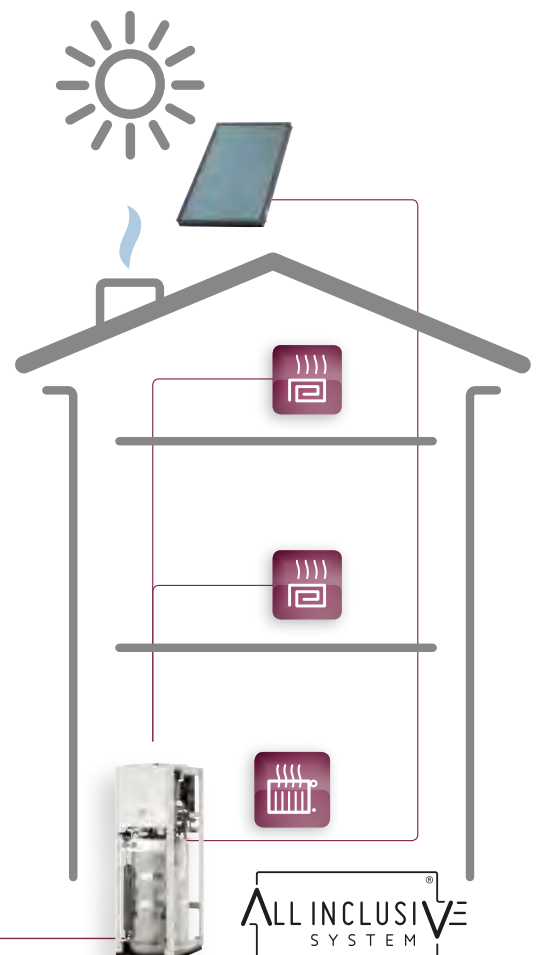

FULL SYSTEM® SERIES

24 kW Instantaneous boiler and 200 l. solar tank combined with a high efficiency panel and brackets for sloping surfaces.

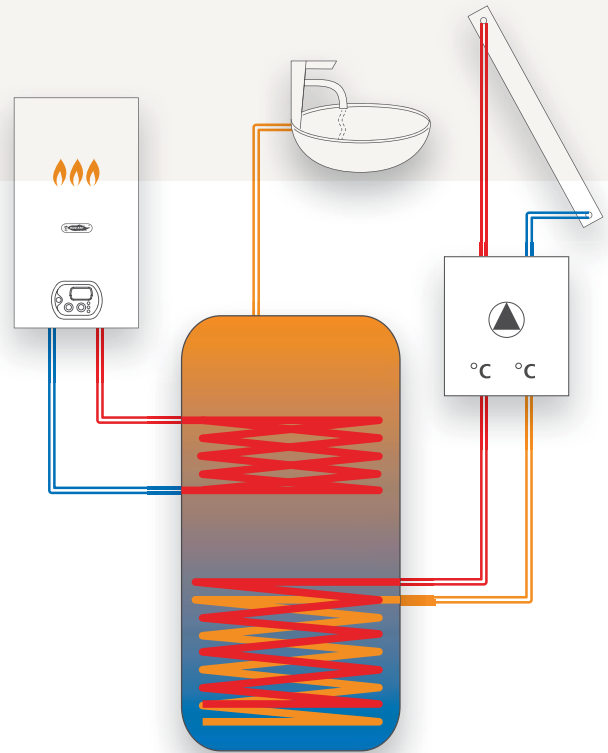

COMBI-TECH R1K 24 /B



STORAGE TANK COMPLETE WITH SOLAR SYSTEM

Complete and totally modular solar system, offering many advantages: a wide choice among the range of Radiant boilers, and among the range of tanks, a total flexibility of the elements to be chosen in the system. Thanks to these features, this product is totally suitable for any solution.



HIGH EFFICIENCY SOLAR PANEL



STAINLESS STEEL BRACKETS FOR SLOPING SURFACES



ACCESSORIES FOR SOLAR SYSTEMS



EN 12975 certified **SOLAR PANELS** having the following specs: casing in painted aluminium profile with thermal insulation 45 mm High Density Rockwool (40 mm for RH1S), matrix entirely in copper with 22 mm Ø collector tubes, full surface absorber with highly selective Titanium coating ultrasonically welded, prismatic tempered ultra-clear anti-reflective glass.

RH1T

Technical data: dimensions 2007x1008x100 mm; aluminium frame, ultra clear tempered glass; effective area **1,77 M²**, gross area **2 M²**;

RH1S

Technical data: dimensions 2000x1000x90 mm; aluminium frame, ultra clear tempered glass; effective area **1,84 M²**, gross area **2 M²**;

RH1TX

Technical data: dimensions 2005x1290x100 mm; aluminium frame, ultra clear tempered glass; effective area **2,5 M²**, gross area **2,5 M²**;

RH10 - Horizontal

Technical data: dimensions 1008x2007x100 mm; aluminium frame, ultra clear tempered glass; effective area **1,77 m²**, gross area **2 m²**;



THERMAL SOLAR PANELS

These systems are the ideal solution for areas characterized by mild climate and constant solar irradiation and when energy savings and easy installations are necessary. We propose 4 packages for visible cylinders on panels and 4 different packages for hidden tank under panels, according to the tank capacity: 150 BASIC / 150 HIDE - 160 PLUS / 160 HIDE - 200 PLUS / 200 HIDE 300 PLUS / 300 HIDE. They are completed with: electric resistance from 1,5 kW, frame for flat or sloped surfaces, 3 bar solar safety valve, 6 bar safety valve in D.H.W. circuit and glycol.

EKOSOLAR MIX, KIT FOR SOLAR INTEGRATION



Max. temperature	100 °C
Max. / Min. working pressure	10 bar / 1 bar
Water connections	1/2 "

New water mixer, which allows to connect an instantaneous combi tank or water-heater to a solar panel installation and a solar storage cylinder in an existing system. Thanks to the configuration using 3-ways valves and a mixing valve, the boiler fires to complement the solar system only when necessary and ensures a supply of domestic hot water at constant and controlled temperature.

EKOSOLAR MIX PERMETTE:

- be installed on all instantaneous combi boiler models,
- totally exclude the boiler, thus increasing its life cycle, when the temperature of the water coming from the panel is equal or higher the one that requested by the user,
- deliver greater energy saving at minor costs for the user,
- guarantee constant D.H.W. temperature as set by the user.

STORAGE TANK COMPLETE WITH SOLAR SYSTEM®. Range of integrated storage tank for solar system and production of domestic hot water with 1 or 2 coils in carbon steel, complete with solar system, control module, solar expansion vessel, 8-bar pressure relief valve and thermostatic mixing valve, complete with mounting brackets. 200, 300 and 500 l. capacity.



COMPLETE SOLAR CIRCULATION UNIT. Composed by: circulation pump, pressure relief valve for solar systems, filling/drain valve, instrument fitting with water pressure gauge, flow control valve with viewer, flow thermometer, return thermometer, pre-formed shell insulation, intercept valve, return check valve, connection for expansion vessel.



STORAGE TANK WITH 1 OR 2 COILS. Range of integrated storage tank for solar systems and production of domestic hot water with 1 or 2 coils in carbon steel, complete with cathodic protection. Storage capacity from 200 to 2.000 l.



SERIE BOILER MINIKOMBI. Range of high quality double storage tanks for heat pumps. Ideal for systems powered by multiple energy sources: gas, electric and solar. Available in 300 and 450 Lt capacity



NEW PRODUCT



COMFORT

HEATING ONLY RS - RS /B

- Boilers for the central heating only or equipped with three-ways-valve and piping for easy addition of an indirect tank
- Copper made main heat exchanger, double ranges, ample passages
- Extremely compact dimensions
- Digitech TR main P.C.B.
- Available also in the open flue version (RC or RC /B)



RS 24 - RS 24 /B **24 kW** RS 28 - RS 28 /B **27 kW** RS 32 - RS 32 /B **32 kW**

Efficiency	***	***	***
Room	sealed	sealed	sealed
Output	24 kW	28 kW	32 kW
Dimensions	410x270x730 mm	450x330x800 mm	450x330x800 mm

COMFORT

ISTANTANEOUS RSR - RCR

- Boilers for the central heating and instantaneous D.H.W. production
- New components, copper made
- Easy access and maintenance
- Digitech TR main P.C.B.
- Available both the open flue (RCR) and room sealed fanned flue (RSR) series
- Two separate exchangers (monothermic version)



RSR 24 **24 kW** RSR 28 **28 kW** RSR 32 **32 kW**

Efficiency	***	***	***
Room	sealed	sealed	sealed
Output	24 kW	28 kW	32 kW
D.H.W. Flow at 40°C (Δt 30°C)	11,5 lt./min	13,3 lt./min	15,5 lt./min
Dimensions	410x270x730 mm	450x330x800 mm	450x330x800 mm

ENERGY INSTANTANEOUS COMBINATION RBS - RBC

- Boilers for the central heating and instantaneous D.H.W. production thru one integrated exchanger
- Extremely compact dimensions thanks to the side expansion vessel
- Digitech TR main P.C.B.
- Available both the open flue (RBC) and room sealed fanned (RBS) flue series
- Integrated exchanger, two ranges and 7 passages



RBS 24 **24 kW** RBC 24 **24 kW**

	RBS 24 24 kW	RBC 24 24 kW
Efficiency	★ ★ ★	★ ★
Room	sealed	open
Output	24 kW	24 kW
D.H.W. Flow at 40°C (Δt 30°C)	11,4 lt./min	11 lt./min
Dimensions	410x270x730 mm	410x320x730 mm

MAXICOMFORT STORAGE RSA /8 RSA /25 - RCA /25

- Boilers for the central heating and D.H.W. production thru a glass-lined storage tank of 8 and 25 l.
- Duopass® system: stunning sanitary performances, regardless the small capacity of the D.H.W. tank
- Easy access and maintenance
- Digitech TR main P.C.B.
- Available both the open flue (RCA) and room sealed fanned flue (RSA) series. Integrated exchanger, 2 ranges and 7 passages



RSA 24 /8 **24 kW** RCA 28 /25 **28 kW** RSA 28 /25 **28 kW** RSA 32 /25 **32 kW**

	RSA 24 /8 24 kW	RCA 28 /25 28 kW	RSA 28 /25 28 kW	RSA 32 /25 32 kW
Efficiency	★ ★ ★	★ ★	★ ★ ★	★ ★ ★
Room	sealed	open	sealed	sealed
Output	20 kW	28 kW	28 kW	32 kW
Storage tank capacity	8 lt.	25 lt.	25 lt.	25 lt.
D.H.W. Flow at 40°C (Δt 30°C)	130 lt./10min	149 lt./10min	150 lt./10min	172 lt./10min
Dimensions	410x270x730 mm	450x330x800 mm	450x330x800 mm	450x330x800 mm



SUPREMA

FLOOR STANDING

RSG - RCG - RSA /40 - RCA /40

- Floor standing gas boilers, for central heating only and D.H.W. production thru a glass-lined storage tank of 40 l. capacity
- Outputs 28 and 32 kW
- Duopass® system: stunning sanitary performances, regardless the small capacity of the D.H.W. tank
- Easy access and maintenance
- Digitech TR main P.C.B. Available both the open flue and room sealed fanned flue series



	RSG 28	28 kW	RSG 32	32 kW	RSA 28 /40	28 kW	RSA 32 /40	32 kW
Efficiency	***		***		***		***	
Room	sealed		sealed		sealed		sealed	
Output	28 kW		32 kW		28 kW		32 kW	
Storage tank capacity	-		-		40 lt.		40 lt.	
D.H.W. Flow at 40°C (Δt 30°C)	-		-		176 lt./10 min.		197 lt./10 min.	
Dimensions	450x655x850 mm		450x655x850 mm		600x650x845 mm		600x650x845 mm	

SUPREMA

FLOOR STANDING

RSA /100 - RCA /100

- Floor standing boilers for the central heating and D.H.W. production through a glass-lined storage tank of 100 l. capacity
- Duopass System®: stunning sanitary performances
- Easy access and maintenance
- Digitech® TR main P.C.B.
- Available both the open flue (RCA) and room sealed fanned flue (RSA) series



	RSG 28	28 kW	RSG 32	32 kW	RSA 28 /40	28 kW
Efficiency	***		***		*	
Room	sealed		sealed		open	
Output	28 kW		32 kW		28 kW	
Storage tank capacity	100 lt.		100 lt.		100 lt.	
D.H.W. Flow at 40°C (Δt 30°C)	247 lt./10 min.		263 lt./10 min.		255 lt./10 min.	
Dimensions	570x570x1640 mm		570x570x1640 mm		570x570x1640 mm	

ENERGY RAIN - COMFORT RAIN - MAXICOMFORT RAIN

ISTANTANEOUS COMBI - COMBI - STORAGE OUT DOOR

RBS - RSR - RSA /8

- Boilers for central heating only, istantaneous combi, storage
- Specifically designed outdoor cabinet to resist to weathering
- Electrical IP degree X5D
- Easy access and maintenance
- Digitech TR main P.C.B. Anti-frost protection
- Integrated exchanger, 2 ranges and 7 passages



	RBS	24 kW	RSA /8	24 kW	RSR	24 - 28 - 32 kW	RAIN	24 - 28 kW
	istantaneous combi		storage		istantaneous		heating only	
Efficiency	★★★		★★★		★★★		★★★	
Room	sealed		sealed		sealed		sealed	
Output	24 kW		24 kW		24 /28 / 32 kW		24 /28 kW	
Electrical IP degree	X5D		X5D		X5D		X5D	
Dimensions	530x270x840 mm		500x280x800 mm		740x255x760 mm		530x270x840 mm	

FLUTRONIC

WATER HEATER S - SF

- Gas instantaneous water heater
- Fully diagnostics
- Easy access and maintenance. P.C.B. and solar integration



	S 14	24 kW	SF 14	27 kW
Efficiency	-		-	
Room	open		sealed	
Output	24 kW		24 kW	
D.H.W. Flow at 40°C (Δt 30°C)	11,2 lt./min.		11,4 lt./min.	
Dimensions	390x245x710 mm		390x245x710 mm	



DIGITECH[®] CS DIGITECH ELECTRONIC BOARD



DIGITECH

RADIANT ELECTRONIC EVOLUTION

- DIGITECH ELECTRONIC BOARD
- MEMORY FUNCTION WITH LAST 5 BOILER ERRORS DISPLAY
- HIGH LEVEL OF ELECTRICAL PROTECTION
- EASY USE

Designed to be attractive and to be easily used, DIGITECH® CS electronic board has both aesthetic and practical contents. Thanks to its design, to the color, to the easy keys and to the operation simpleness, it fits every room of the house and allows the settings in a very simple and intuitive way.

DIGITECH® allows a steady control of the operating parameters and the fast identification of any anomalies through specific codes, and the Memory function allows the technician to check for the last 5 errors displayed on the LCD panel.

DIGITECH® shows the boiler operating temperatures together with the possibility of temperature adjustments with 1° progression and enlists the possibility of control of external sensors, solar panels and storage tank external sensors. DIGITECH® CS is installed in every Radiant condensing boiler.



RADIANT CLOUDWARM BOILER MODULATING REMOTE CONTROL

MANAGE YOUR COMFORT AND SAVE

With the new Cloud Warm App, you can manage your home comfort directly from your smartphone or tablet. Just a finger touch to set your comfort, you can control, regulate and program all the parameters to manage your system.

In case of failure, errors can be reset from remote, thus restoring the normal boiler operations and re-establishing domestic comfort.

It is possible to select thermoregulation through the interaction between external sensor-room sensor-remote control, in order to reduce costs and optimize comfort. The heating operation is therefore modulated according to the outdoor temperature and the user's settings. With this function, manageable from remote, unnecessary energy and money wastes are reduced.

Cloudwarm can be work with all Radiant products with remote functionality (starting from 2013) and is compatible with all previous products with chrono-thermostat functionality.



DOWNLOAD THE FREE APP FOR IOS AND ANDROID

**SIMPLE AND INTUITIVE COMMANDS
FROM SMARTPHONE OR TABLET**

THE COMFORT AT HOME WHEN YOU WANT

**REMOTE CONNECTION TO PLAN
THE DAY OR THE WEEK**





Dati tecnici e misure non sono impegnativi. La Ditta si riserva il diritto di eventuali variazioni senza l'obbligo di preavviso.
Decliniamo ogni responsabilità per eventuali inesattezze contenute nel presente opuscolo, se dovute ad errori di stampa o di trascrizione. E+OE

RADIANT BRUCIATORI spa _ via Pantanelli 164/166 _ 61025 Montelabbate (PU) Italy _ ph. +39 0721 90791 _ fax +39 0721 9079299 _ info@radiant.it _ www.radiant.it